



Solution manual of thomas I floyd

Mechanics of Solids (Ghulam Ishaq Khan Institute of Engineering Sciences and
Technology)



Scan to open on Studocu

PART 1

Solutions
for
End-of-Chapter Problems

Chapter 1

Quantities and Units

Section 1-2 Scientific Notation

1. (a) $3000 = 3 \times 10^3$ (b) $75,000 = 7.5 \times 10^4$ (c) $2,000,000 = 2 \times 10^6$
2. (a) $\frac{1}{500} = 0.002 = 2 \times 10^{-3}$
- (b) $\frac{1}{2000} = 0.0005 = 5 \times 10^{-4}$
- (c) $\frac{1}{5,000,000} = 0.0000002 = 2 \times 10^{-7}$
3. (a) $8400 = 8.4 \times 10^3$ (b) $99,000 = 9.9 \times 10^4$ (c) $0.2 \times 10^6 = 2 \times 10^5$
4. (a) $0.0002 = 2 \times 10^{-4}$ (b) $0.6 = 6 \times 10^{-1}$
- (c) 7.8×10^{-2} (already in scientific notation)
5. (a) $32 \times 10^3 = 3.2 \times 10^4$
- (b) $6800 \times 10^{-6} = 6.8 \times 10^{-3}$
- (c) $870 \times 10^8 = 8.7 \times 10^{10}$
6. (a) $2 \times 10^5 = 200,000$
- (b) $5.4 \times 10^{-9} = 0.0000000054$
- (c) $1.0 \times 10^1 = 10$
7. (a) $2.5 \times 10^{-6} = 0.0000025$ (b) $5.0 \times 10^2 = 500$ (c) $3.9 \times 10^{-1} = 0.39$
8. (a) $4.5 \times 10^{-6} = 0.0000045$
- (b) $8 \times 10^{-9} = 0.000000008$
- (c) $4.0 \times 10^{-12} = 0.0000000000040$

9. (a) $9.2 \times 10^6 + 3.4 \times 10^7 = 9.2 \times 10^6 + 34 \times 10^6 = 4.32 \times 10^7$
 (b) $5 \times 10^3 + 8.5 \times 10^{-1} = 5 \times 10^3 + 0.00085 \times 10^3 = 5.00085 \times 10^3$
 (c) $5.6 \times 10^{-8} + 4.6 \times 10^{-9} = 56 \times 10^{-9} + 4.6 \times 10^{-9} = 6.06 \times 10^{-8}$
10. (a) $3.2 \times 10^{12} - 1.1 \times 10^{12} = 2.1 \times 10^{12}$
 (b) $2.6 \times 10^8 - 1.3 \times 10^7 = 26 \times 10^7 - 1.3 \times 10^7 = 24.7 \times 10^7$
 (c) $1.5 \times 10^{-12} - 8 \times 10^{-13} = 15 \times 10^{-13} - 8 \times 10^{-13} = 7 \times 10^{-13}$
11. (a) $(5 \times 10^3)(4 \times 10^5) = 5 \times 4 \times 10^{3+5} = 20 \times 10^8 = 2.0 \times 10^9$
 (b) $(1.2 \times 10^{12})(3 \times 10^2) = 1.2 \times 3 \times 10^{12+2} = 3.6 \times 10^{14}$
 (c) $(2.2 \times 10^{-9})(7 \times 10^{-6}) = 2.2 \times 7 \times 10^{-9-6} = 15.4 \times 10^{-15} = 1.54 \times 10^{-14}$
12. (a) $\frac{1.0 \times 10^3}{2.5 \times 10^2} = 0.4 \times 10^{3-2} = 0.4 \times 10^1 = 4$
 (b) $\frac{2.5 \times 10^{-6}}{50 \times 10^{-8}} = 0.05 \times 10^{-6-(-8)} = 0.05 \times 10^2 = 5$
 (c) $\frac{4.2 \times 10^8}{2 \times 10^{-5}} = 2.1 \times 10^{8-(-5)} = 2.1 \times 10^{13}$

Section 1-3 Engineering Notation and Metric Prefixes

13. (a) $89000 = 89 \times 10^3$
 (b) $450,000 = 450 \times 10^3$
 (c) $12,040,000,000,000 = 12.04 \times 10^{12}$
14. (a) $2.35 \times 10^5 = 235 \times 10^3$
 (b) $7.32 \times 10^7 = 73.2 \times 10^6$
 (c) 1.333×10^9 (already in engineering notation)
15. (a) $0.000345 = 345 \times 10^{-6}$
 (b) $0.025 = 25 \times 10^{-3}$
 (c) $0.00000000129 = 1.29 \times 10^{-9}$

16. (a) $9.81 \times 10^{-3} = \mathbf{9.81 \times 10^{-3}}$
 (b) $4.82 \times 10^{-4} = \mathbf{482 \times 10^{-6}}$
 (c) $4.38 \times 10^{-7} = \mathbf{438 \times 10^{-9}}$
17. (a) $2.5 \times 10^{-3} + 4.6 \times 10^{-3} = (2.5 + 4.6) \times 10^{-3} = \mathbf{7.1 \times 10^{-3}}$
 (b) $68 \times 10^6 + 33 \times 10^6 = (68 + 33) \times 10^6 = \mathbf{101 \times 10^6}$
 (c) $1.25 \times 10^6 + 250 \times 10^3 = 1.25 \times 10^6 + 0.25 \times 10^6 = (1.25 + 0.25) \times 10^6 = \mathbf{1.50 \times 10^6}$
18. (a) $(32 \times 10^{-3})(56 \times 10^3) = 1792 \times 10^{(-3+3)} = 1792 \times 10^0 = \mathbf{1.792 \times 10^3}$
 (b) $(1.2 \times 10^{-6})(1.2 \times 10^{-6}) = 1.44 \times 10^{(-6-6)} = \mathbf{1.44 \times 10^{-12}}$
 (c) $(100)(55 \times 10^{-3}) = 5500 \times 10^{-3} = \mathbf{5.5}$
19. (a) $\frac{50}{2.2 \times 10^3} = \mathbf{22.7 \times 10^{-3}}$
 (b) $\frac{5 \times 10^3}{25 \times 10^{-6}} = 0.2 \times 10^{(3-(-6))} = 0.2 \times 10^9 = \mathbf{200 \times 10^6}$
 (c) $\frac{560 \times 10^3}{660 \times 10^3} = 0.848 \times 10^{(3-3)} = 0.848 \times 10^0 = \mathbf{848 \times 10^{-3}}$
20. (a) $89,000 = 89 \times 10^3 = \mathbf{89 \text{ k}}$
 (b) $450,000 = 450 \times 10^3 = \mathbf{450 \text{ k}}$
 (c) $12,040,000,000,000 = 12.04 \times 10^{12} = \mathbf{12.04 \text{ T}}$
21. (a) $0.000345 \text{ A} = 345 \times 10^{-6} \text{ A} = \mathbf{345 \mu\text{A}}$
 (b) $0.025 \text{ A} = 25 \times 10^{-3} \text{ A} = \mathbf{25 \text{ mA}}$
 (c) $0.00000000129 \text{ A} = 1.29 \times 10^{-9} \text{ A} = \mathbf{1.29 \text{ nA}}$
22. (a) $31 \times 10^{-3} \text{ A} = \mathbf{31 \text{ mA}}$ (b) $5.5 \times 10^3 \text{ V} = \mathbf{5.5 \text{ kV}}$ (c) $20 \times 10^{-12} \text{ F} = \mathbf{20 \text{ pF}}$
23. (a) $3 \times 10^{-6} \text{ F} = \mathbf{3 \mu\text{F}}$ (b) $3.3 \times 10^6 \Omega = \mathbf{3.3 \text{ M}\Omega}$ (c) $350 \times 10^{-9} \text{ A} = \mathbf{350 \text{ nA}}$
24. (a) $2.5 \times 10^{-12} \text{ A} = \mathbf{2.5 \text{ pA}}$
 (b) $8 \times 10^9 \text{ Hz} = \mathbf{8 \text{ GHz}}$
 (c) $4.7 \times 10^3 \Omega = \mathbf{4.7 \text{ k}\Omega}$

25. (a) $7.5 \text{ pA} = 7.5 \times 10^{-12} \text{ A}$
 (b) $3.3 \text{ GHz} = 3.3 \times 10^9 \text{ Hz}$
 (c) $280 \text{ nW} = 2.8 \times 10^{-7} \text{ W}$
26. (a) $5 \text{ } \mu\text{A} = 5 \times 10^{-6} \text{ A}$ (b) $43 \text{ mV} = 43 \times 10^{-3} \text{ V}$
 (c) $275 \text{ k}\Omega = 275 \times 10^3 \Omega$ (d) $10 \text{ MW} = 10 \times 10^6 \text{ W}$

Section 1-4 Metric Unit Conversions

27. (a) $(5 \text{ mA})(1 \times 10^3 \text{ } \mu\text{A}/\text{mA}) = 5 \times 10^3 \text{ } \mu\text{A} = 5000 \text{ } \mu\text{A}$
 (b) $(3200 \text{ } \mu\text{W})(1 \times 10^{-3} \text{ W}/\text{ } \mu\text{W}) = 3.2 \text{ mW}$
 (c) $(5000 \text{ kV})(1 \times 10^{-3}) \text{ MV}/\text{kV} = 5 \text{ MV}$
 (d) $(10 \text{ MW})(1 \times 10^3 \text{ kW}/\text{MW}) = 10 \times 10^3 \text{ kW} = 10,000 \text{ kW}$
28. (a) $\frac{1 \text{ mA}}{1 \text{ } \mu\text{A}} = \frac{1 \times 10^{-3} \text{ A}}{1 \times 10^{-6} \text{ A}} = 1 \times 10^3 = 1000$
 (b) $\frac{0.05 \text{ kV}}{1 \text{ mV}} = \frac{0.05 \times 10^3 \text{ V}}{1 \times 10^{-3} \text{ V}} = 0.05 \times 10^6 = 50,000$
 (c) $\frac{0.02 \text{ k}\Omega}{1 \text{ M}\Omega} = \frac{0.02 \times 10^3 \Omega}{1 \times 10^6 \Omega} = 0.02 \times 10^{-3} = 2 \times 10^{-5}$
 (d) $\frac{155 \text{ mW}}{1 \text{ kW}} = \frac{155 \times 10^{-3} \text{ W}}{1 \times 10^3 \text{ W}} = 155 \times 10^{-6} = 1.55 \times 10^{-4}$
29. (a) $50 \text{ mA} + 680 \text{ } \mu\text{A} = 50 \text{ mA} + 0.68 \text{ mA} = 50.68 \text{ mA}$
 (b) $120 \text{ k}\Omega + 2.2 \text{ M}\Omega = 0.12 \text{ M}\Omega + 2.2 \text{ M}\Omega = 2.32 \text{ M}\Omega$
 (c) $0.02 \text{ } \mu\text{F} + 3300 \text{ pF} = 0.02 \text{ } \mu\text{F} + 0.0033 \text{ } \mu\text{F} = 0.0233 \text{ } \mu\text{F}$
30. (a) $\frac{10 \text{ k}\Omega}{2.2 \text{ k}\Omega + 10 \text{ k}\Omega} = \frac{10 \text{ k}\Omega}{12.2 \text{ k}\Omega} = 0.8197$
 (b) $\frac{250 \text{ mV}}{50 \text{ } \mu\text{V}} = \frac{250 \times 10^{-3}}{50 \times 10^{-6}} = 5000$
 (c) $\frac{1 \text{ MW}}{2 \text{ kW}} = \frac{1 \times 10^6}{2 \times 10^3} = 500$

Chapter 2

Voltage, Current, and Resistance

Note: Solutions show conventional current direction.

Section 2-2 Electrical Charge

1. $29 \text{ e} \times 1.6 \times 10^{-19} \text{ C/e} = 4.64 \times 10^{-18} \text{ C}$
2. $17 \text{ e} \times 1.6 \times 10^{-19} \text{ C/e} = 2.72 \times 10^{-18} \text{ C}$
3. $Q = (\text{charge per electron})(\text{number of electrons}) = (1.6 \times 10^{-19} \text{ C/e})(50 \times 10^{31} \text{ e}) = 80 \times 10^{12} \text{ C}$
4. $(6.25 \times 10^{18} \text{ e/C})(80 \times 10^{-6} \text{ C}) = 5 \times 10^{14} \text{ electrons}$

Section 2-3 Voltage, Current, and Resistance

5. (a) $V = \frac{W}{Q} = \frac{10 \text{ J}}{1 \text{ C}} = 10 \text{ V}$ (b) $V = \frac{W}{Q} = \frac{5 \text{ J}}{2 \text{ C}} = 2.5 \text{ V}$
(c) $V = \frac{W}{Q} = \frac{100 \text{ J}}{25 \text{ C}} = 4 \text{ V}$
6. $V = \frac{W}{Q} = \frac{500 \text{ J}}{100 \text{ C}} = 5 \text{ V}$
7. $V = \frac{W}{Q} = \frac{800 \text{ J}}{40 \text{ C}} = 20 \text{ V}$
8. $W = VQ = (12 \text{ V})(2.5 \text{ C}) = 30 \text{ J}$
9. $I = \frac{Q}{t}$
 $Q = It = (2 \text{ A})(15 \text{ s}) = 30 \text{ C}$
 $V = \frac{W}{Q} = \frac{1000 \text{ J}}{30 \text{ C}} = 33.3 \text{ V}$
10. (a) $I = \frac{Q}{t} = \frac{75 \text{ C}}{1 \text{ s}} = 75 \text{ A}$
(b) $I = \frac{Q}{t} = \frac{10 \text{ C}}{0.5 \text{ s}} = 20 \text{ A}$
(c) $I = \frac{Q}{t} = \frac{5 \text{ C}}{2 \text{ s}} = 2.5 \text{ A}$

11. $I = \frac{Q}{t} = \frac{0.6 \text{ C}}{3 \text{ s}} = \mathbf{0.2 \text{ A}}$
12. $I = \frac{Q}{t}$
 $t = \frac{Q}{I} = \frac{10 \text{ C}}{5 \text{ A}} = \mathbf{2 \text{ s}}$
13. $Q = It = (1.5 \text{ A})(0.1 \text{ s}) = \mathbf{0.15 \text{ C}}$
14. $I = \frac{Q}{t}$
 $Q = \frac{574 \times 10^{15} \text{ electrons}}{6.25 \times 10^{18} \text{ electrons/C}} = 9.18 \times 10^{-2} \text{ C}$
 $I = \frac{9.18 \times 10^{-2} \text{ C}}{250 \times 10^{-3} \text{ s}} = \mathbf{367 \text{ mA}}$
15. (a) $G = \frac{1}{R} = \frac{1}{5 \Omega} = 0.2 \text{ S} = \mathbf{200 \text{ mS}}$
 (b) $G = \frac{1}{R} = \frac{1}{25 \Omega} = 0.04 \text{ S} = \mathbf{40 \text{ mS}}$
 (c) $G = \frac{1}{R} = \frac{1}{100 \Omega} = 0.01 \text{ S} = \mathbf{10 \text{ mS}}$
16. (a) $R = \frac{1}{G} = \frac{1}{0.1 \text{ S}} = \mathbf{10 \Omega}$
 (b) $R = \frac{1}{G} = \frac{1}{0.5 \text{ S}} = \mathbf{2 \Omega}$
 (c) $R = \frac{1}{G} = \frac{1}{0.02 \text{ S}} = \mathbf{50 \Omega}$

Section 2-4 Voltage and Current Sources

17. Four common sources of voltage are **dc power supply, solar cell, generator, and battery.**
18. The operation of electrical generators is based on the principle of **electromagnetic induction.**
19. A power supply converts electricity in one form (ac) to another form (dc). The other sources convert other forms of energy into electrical energy.
20. Since the resistance is reduced by one half, the current in the load doubles to **200 mA.**

Chapter 2

Section 2-5 Resistors

21. (a) Red, violet, orange, gold: $27 \text{ k}\Omega \pm 5\%$
(b) Brown, gray, red, silver: $1.8 \text{ k}\Omega \pm 10\%$
22. (a) $R_{min} = 27 \text{ k}\Omega - 0.05(27 \text{ k}\Omega) = 27 \text{ k}\Omega - 1350 \Omega = 25.65 \text{ k}\Omega$
 $R_{max} = 27 \text{ k}\Omega + 0.05(27 \text{ k}\Omega) = 27 \text{ k}\Omega + 1350 \Omega = 28.35 \text{ k}\Omega$
(b) $R_{min} = 1.8 \text{ k}\Omega - 0.1(1.8 \text{ k}\Omega) = 1.8 \text{ k}\Omega - 180 \Omega = 1.62 \text{ k}\Omega$
 $R_{max} = 1.8 \text{ k}\Omega + 0.1(1.8 \text{ k}\Omega) = 1.8 \text{ k}\Omega + 180 \Omega = 1.98 \text{ k}\Omega$
23. 330 Ω : orange, orange, brown, gold
2.2 k Ω : red, red, red, gold
56 k Ω : green, blue, orange, gold
100 k Ω : brown, black, yellow, gold
39 k Ω : orange, white, orange, gold
24. (a) brown, black, black, gold: $10 \Omega \pm 5\%$
(b) green, brown, green, silver: $5.1 \text{ M}\Omega \pm 10\%$
(c) blue, gray, black, gold: $68 \Omega \pm 5\%$
25. (a) 0.47 Ω : yellow, violet, silver, gold
(b) 270 k Ω : red, violet, yellow, gold
(c) 5.1 M Ω : green, brown, green, gold
26. (a) red, gray, violet, red, brown: $28.7 \text{ k}\Omega \pm 1\%$
(b) blue, black, yellow, gold, brown: $60.4 \pm 1\%$
(c) white, orange, brown, brown, brown: $9.31 \text{ k}\Omega \pm 1\%$
27. (a) $14.7 \text{ k}\Omega \pm 1\%$: brown, yellow, violet, red, brown
(b) $39.2 \Omega \pm 1\%$: orange, white, red, gold, brown
(c) $9.76 \text{ k}\Omega \pm 1\%$: white, violet, blue, brown, brown
28. 500 Ω , There is equal resistance on each side of the contact.
29. 4K7 = 4.7 k Ω
30. (a) 4R7J = 4.7 $\Omega \pm 5\%$
(b) 5602M = 56 k $\Omega \pm 20\%$
(c) 1501F = 1500 $\Omega \pm 1\%$

Section 2-6 The Electric Circuit

31. See Figure 2-1.

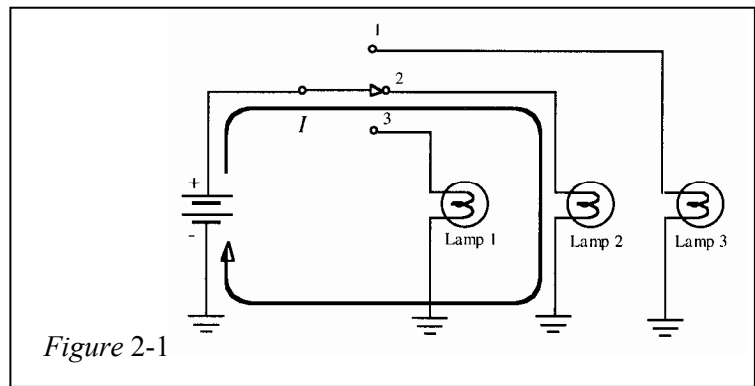

32. See Figure 2-2.

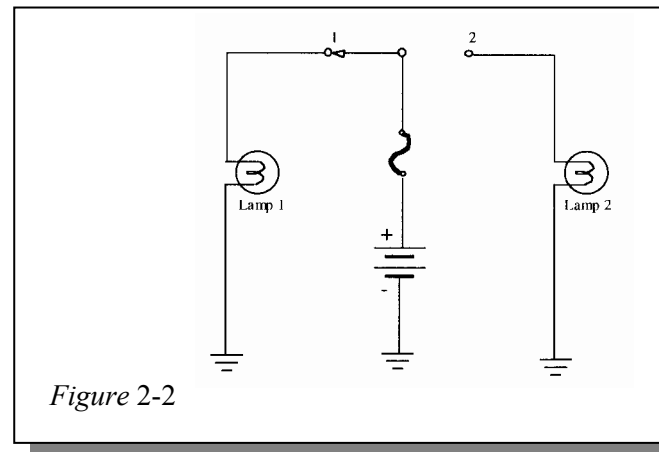

33. Circuit (b) in Figure 2-69 can have both lamps on at the same time.

34. There is always current through R_5 .

Chapter 2

35. See Figure 2-3.

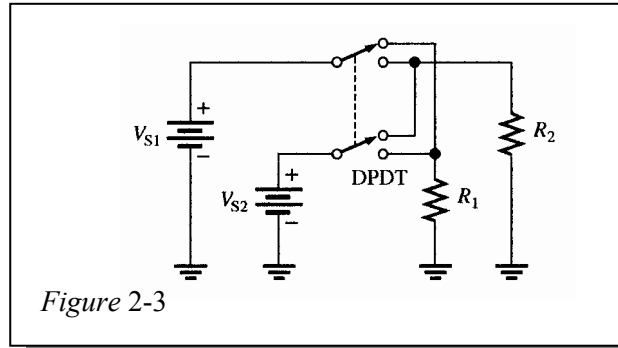

36. See Figure 2-4.

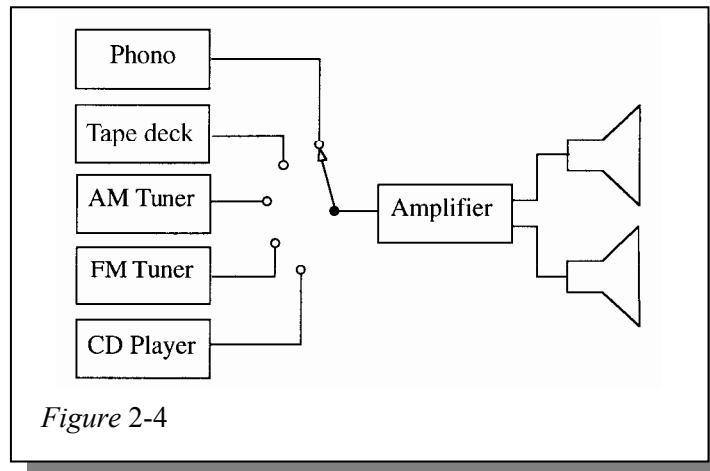

Section 2-7 Basic Circuit Measurements

37. See Figure 2-5.

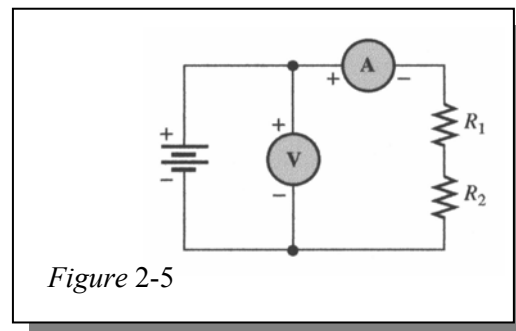

38. See Figure 2-6.

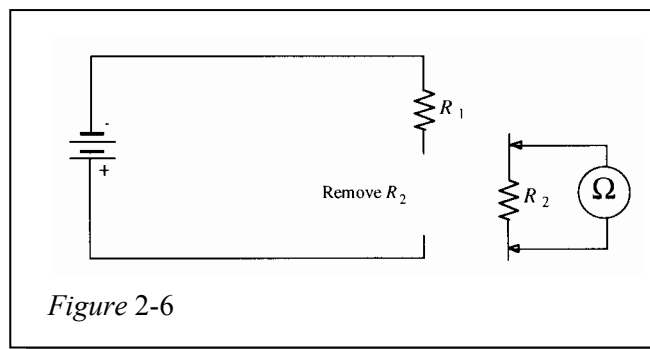

39. **Position 1:** $V_1 = 0 \text{ V}$, $V_2 = V_S$
Position 2: $V_1 = V_S$, $V_2 = 0 \text{ V}$

40. See Figure 2-7.

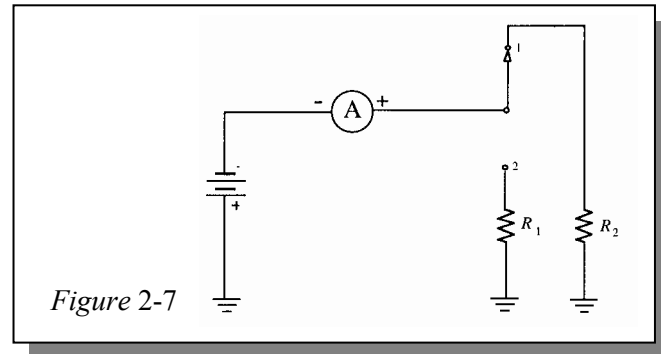

41. See Figure 2-8.

42. See Figure 2-8.

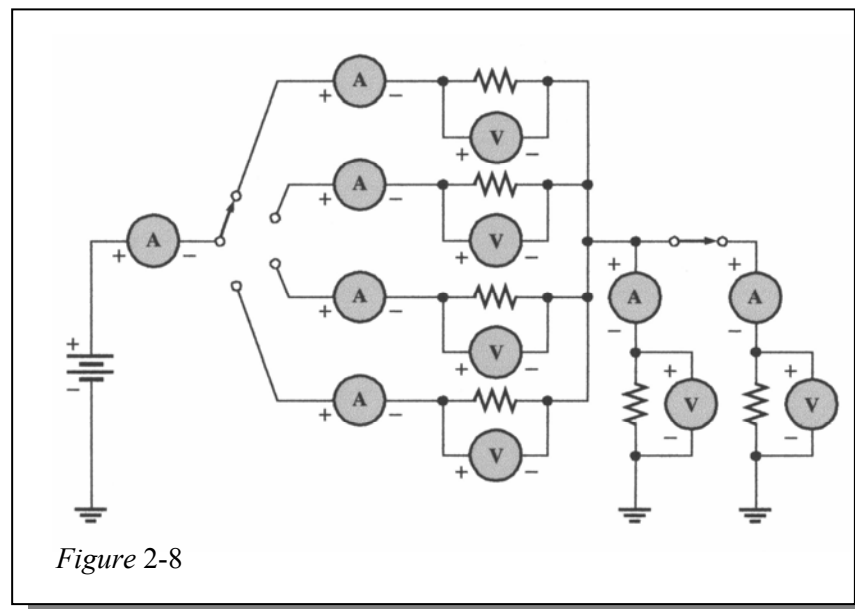

43. On the 600 V scale (middle AC/DC scale): **250 V**

44. $R = 10 \times 10 \ \Omega = \mathbf{100 \ \Omega}$

45. (a) $2 \times 10 \ \Omega = \mathbf{20 \ \Omega}$
 (b) $15 \times 100 \ \text{k}\Omega = \mathbf{1.50 \ \text{M}\Omega}$
 (c) $45 \times 100 \ \Omega = \mathbf{4.5 \ \text{k}\Omega}$

46. $0.9999 + 0.0001 = 1.0000$
 Resolution = **0.00001 V**

Chapter 2

47. See Figure 2-9.

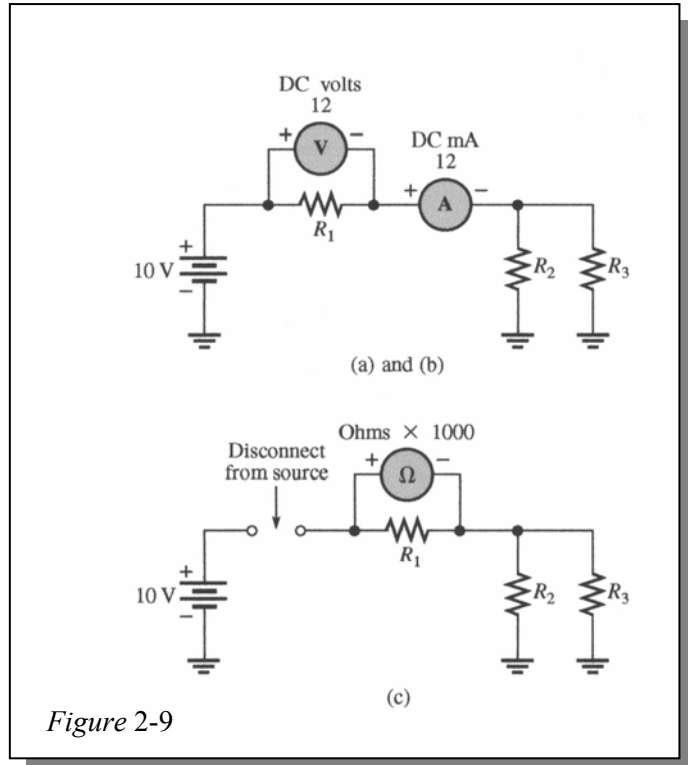

Figure 2-9

Chapter 3

Ohm's Law

Note: Solutions show conventional current direction.

Section 3-1 The Relationship of Current, Voltage, and Resistance

- When voltage triples, current triples.
 - When voltage is reduced 75%, current is reduced 75%.
 - When resistance is doubled, current is halved.
 - When resistance is reduced 35%, current increases 54%.
 - When voltage is doubled and resistance is halved, current quadruples.
 - When voltage and resistance are both doubled, current is unchanged.

2. $I = \frac{V}{R}$

3. $V = IR$

4. $R = \frac{V}{I}$

5. See Figure 3-1.

$$I = \frac{0 \text{ V}}{100 \Omega} = 0 \text{ A}$$

$$I = \frac{10 \text{ V}}{100 \Omega} = 100 \text{ mA}$$

$$I = \frac{20 \text{ V}}{100 \Omega} = 200 \text{ mA}$$

$$I = \frac{30 \text{ V}}{100 \Omega} = 300 \text{ mA}$$

$$I = \frac{40 \text{ V}}{100 \Omega} = 400 \text{ mA}$$

$$I = \frac{50 \text{ V}}{100 \Omega} = 500 \text{ mA}$$

$$I = \frac{60 \text{ V}}{100 \Omega} = 600 \text{ mA}$$

$$I = \frac{70 \text{ V}}{100 \Omega} = 700 \text{ mA}$$

$$I = \frac{80 \text{ V}}{100 \Omega} = 800 \text{ mA}$$

$$I = \frac{90 \text{ V}}{100 \Omega} = 900 \text{ mA}$$

$$I = \frac{100 \text{ V}}{100 \Omega} = 1 \text{ A}$$

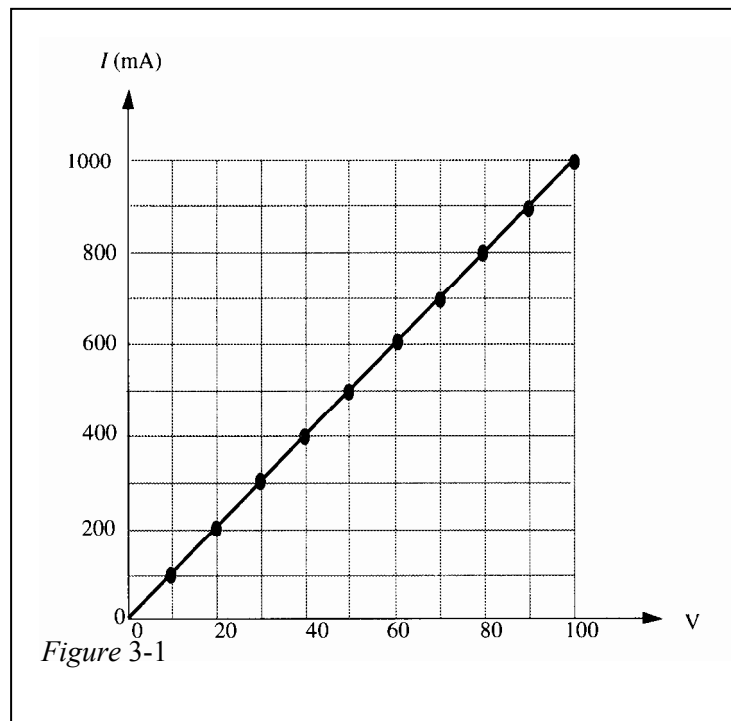

Figure 3-1

The graph is a straight line indicating a linear relationship between V and I .

Chapter 3

6. $R = \frac{1\text{ V}}{15\text{ mA}} = 200\ \Omega$
- (a) $I = \frac{1.5\text{ V}}{200\ \Omega} = 7.5\text{ mA}$
- (b) $I = \frac{2\text{ V}}{200\ \Omega} = 10\text{ mA}$
- (c) $I = \frac{3\text{ V}}{200\ \Omega} = 15\text{ mA}$
- (d) $I = \frac{4\text{ V}}{200\ \Omega} = 20\text{ mA}$
- (e) $I = \frac{10\text{ V}}{200\ \Omega} = 50\text{ mA}$

7. Pick a voltage value and find the corresponding value of current by projecting a line up from the voltage value on the horizontal axis to the resistance line and then across to the vertical axis.

$$R_1 = \frac{V}{I} = \frac{1\text{ V}}{2\text{ A}} = 500\text{ m}\Omega$$

$$R_2 = \frac{V}{I} = \frac{1\text{ V}}{1\text{ A}} = 1\ \Omega$$

$$R_3 = \frac{V}{I} = \frac{1\text{ V}}{0.5\text{ A}} = 2\ \Omega$$

8. See Figure 3-2.

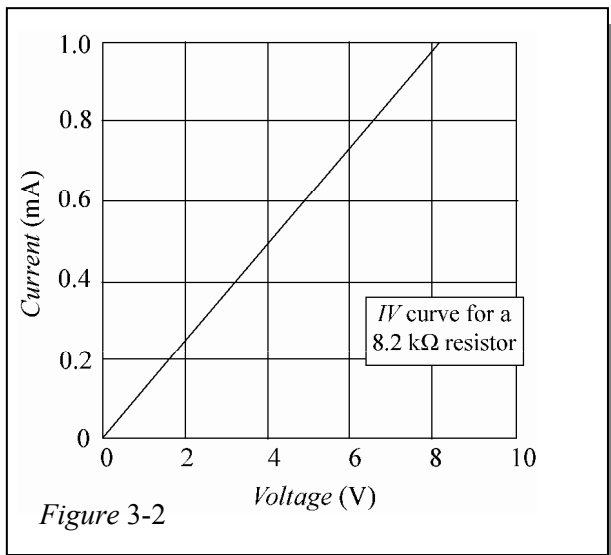

$$I = \frac{2 \text{ V}}{8.2 \text{ k}\Omega} = 0.244 \text{ mA}$$

$$I = \frac{4 \text{ V}}{8.2 \text{ k}\Omega} = 0.488 \text{ mA}$$

$$I = \frac{6 \text{ V}}{8.2 \text{ k}\Omega} = 0.732 \text{ mA}$$

$$I = \frac{8 \text{ V}}{8.2 \text{ k}\Omega} = 0.976 \text{ mA}$$

$$I = \frac{10 \text{ V}}{8.2 \text{ k}\Omega} = 1.22 \text{ mA}$$

9. See Figure 3-3.

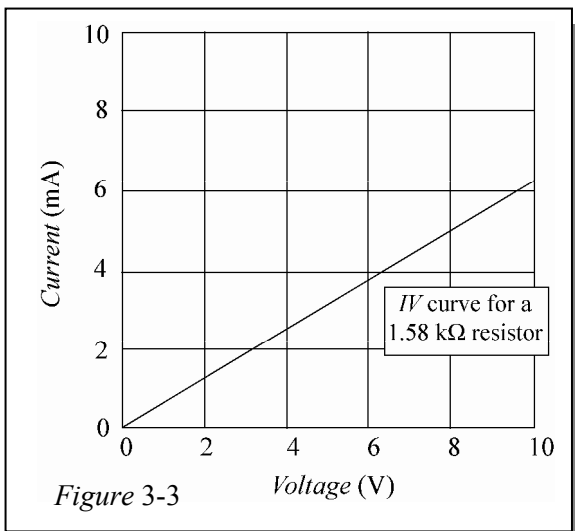

$$I = \frac{2 \text{ V}}{1.58 \text{ k}\Omega} = 1.27 \text{ mA}$$

$$I = \frac{4 \text{ V}}{1.58 \text{ k}\Omega} = 2.53 \text{ mA}$$

$$I = \frac{6 \text{ V}}{1.58 \text{ k}\Omega} = 3.80 \text{ mA}$$

$$I = \frac{8 \text{ V}}{1.58 \text{ k}\Omega} = 5.06 \text{ mA}$$

$$I = \frac{10 \text{ V}}{1.58 \text{ k}\Omega} = 6.33 \text{ mA}$$

Chapter 3

10. (a) $I = \frac{50 \text{ V}}{3.3 \text{ k}\Omega} = 15.2 \text{ mA}$
 (b) $I = \frac{75 \text{ V}}{3.9 \text{ k}\Omega} = 19.2 \text{ mA}$
 (c) $I = \frac{100 \text{ V}}{4.7 \text{ k}\Omega} = 21.3 \text{ mA}$

Circuit (c) has the most current and circuit (a) has the least current.

11. $R = \frac{V_s}{30 \text{ mA}} = \frac{10 \text{ V}}{50 \text{ mA}} = 0.2 \text{ k}\Omega = 200 \Omega$

$V_s = (200 \Omega)(30 \text{ mA}) = 6 \text{ V}$ (new value)

The battery voltage decreased by 4 V (from 10 V to 6 V).

12. The current increase is 50%, so the voltage increase must also be 50%.

$V_{INC} = (0.5)(20 \text{ V}) = 10 \text{ V}$

$V_2 = 20 \text{ V} + V_{INC} = 20 \text{ V} + 10 \text{ V} = \mathbf{30 \text{ V}}$ (new value)

13. See Figure 3-4.

(a) $I = \frac{10 \text{ V}}{1 \Omega} = 10 \text{ A}$	(b) $I = \frac{10 \text{ V}}{5 \Omega} = 2 \text{ A}$	(c) $I = \frac{10 \text{ V}}{20 \Omega} = 0.5 \text{ A}$
$I = \frac{20 \text{ V}}{1 \Omega} = 20 \text{ A}$	$I = \frac{20 \text{ V}}{5 \Omega} = 4 \text{ A}$	$I = \frac{20 \text{ V}}{20 \Omega} = 1 \text{ A}$
$I = \frac{30 \text{ V}}{1 \Omega} = 30 \text{ A}$	$I = \frac{30 \text{ V}}{5 \Omega} = 6 \text{ A}$	$I = \frac{30 \text{ V}}{20 \Omega} = 1.5 \text{ A}$
$I = \frac{40 \text{ V}}{1 \Omega} = 40 \text{ A}$	$I = \frac{40 \text{ V}}{5 \Omega} = 8 \text{ A}$	$I = \frac{40 \text{ V}}{20 \Omega} = 2 \text{ A}$
$I = \frac{50 \text{ V}}{1 \Omega} = 50 \text{ A}$	$I = \frac{50 \text{ V}}{5 \Omega} = 10 \text{ A}$	$I = \frac{50 \text{ V}}{20 \Omega} = 2.5 \text{ A}$
$I = \frac{60 \text{ V}}{1 \Omega} = 60 \text{ A}$	$I = \frac{60 \text{ V}}{5 \Omega} = 12 \text{ A}$	$I = \frac{60 \text{ V}}{20 \Omega} = 3 \text{ A}$
$I = \frac{70 \text{ V}}{1 \Omega} = 70 \text{ A}$	$I = \frac{70 \text{ V}}{5 \Omega} = 14 \text{ A}$	$I = \frac{70 \text{ V}}{20 \Omega} = 3.5 \text{ A}$
$I = \frac{80 \text{ V}}{1 \Omega} = 80 \text{ A}$	$I = \frac{80 \text{ V}}{5 \Omega} = 16 \text{ A}$	$I = \frac{80 \text{ V}}{20 \Omega} = 4 \text{ A}$
$I = \frac{90 \text{ V}}{1 \Omega} = 90 \text{ A}$	$I = \frac{90 \text{ V}}{5 \Omega} = 18 \text{ A}$	$I = \frac{90 \text{ V}}{20 \Omega} = 4.5 \text{ A}$
$I = \frac{100 \text{ V}}{1 \Omega} = 100 \text{ A}$	$I = \frac{100 \text{ V}}{5 \Omega} = 20 \text{ A}$	$I = \frac{100 \text{ V}}{20 \Omega} = 5 \text{ A}$

$$\begin{aligned}
 \text{(d)} \quad I &= \frac{10 \text{ V}}{100 \Omega} = 0.1 \text{ A} \\
 I &= \frac{20 \text{ V}}{100 \Omega} = 0.2 \text{ A} \\
 I &= \frac{30 \text{ V}}{100 \Omega} = 0.3 \text{ A} \\
 I &= \frac{40 \text{ V}}{100 \Omega} = 0.4 \text{ A} \\
 I &= \frac{50 \text{ V}}{100 \Omega} = 0.5 \text{ A} \\
 I &= \frac{60 \text{ V}}{100 \Omega} = 0.6 \text{ A} \\
 I &= \frac{70 \text{ V}}{100 \Omega} = 0.7 \text{ A} \\
 I &= \frac{80 \text{ V}}{100 \Omega} = 0.8 \text{ A} \\
 I &= \frac{90 \text{ V}}{100 \Omega} = 0.9 \text{ A} \\
 I &= \frac{100 \text{ V}}{100 \Omega} = 1 \text{ A}
 \end{aligned}$$

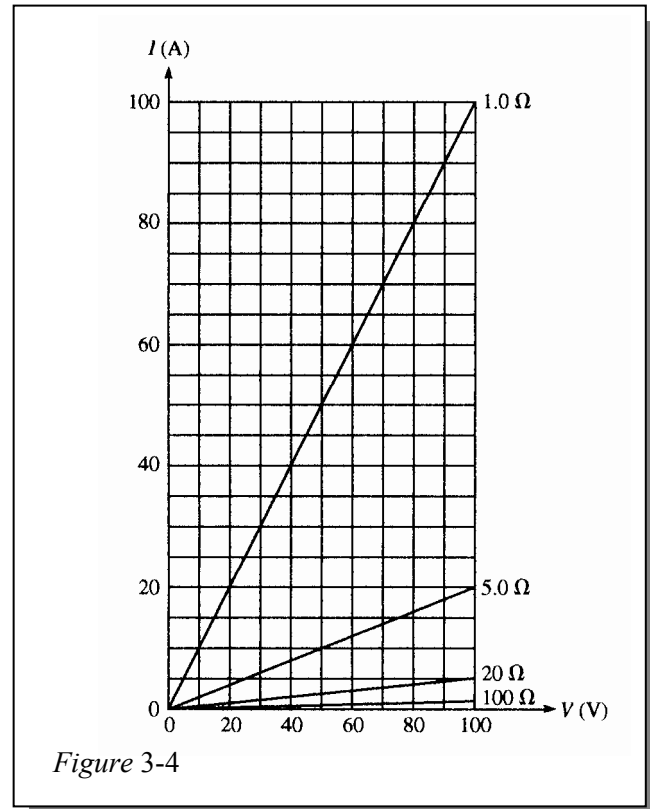

14. Yes, the lines on the IV graph are straight lines.

Section 3-2 Calculating Current

$$\begin{aligned}
 15. \quad \text{(a)} \quad I &= \frac{V}{R} = \frac{5 \text{ V}}{1 \Omega} = 5 \text{ A} \\
 \text{(b)} \quad I &= \frac{V}{R} = \frac{15 \text{ V}}{10 \Omega} = 1.5 \text{ A} \\
 \text{(c)} \quad I &= \frac{V}{R} = \frac{50 \text{ V}}{100 \Omega} = 500 \text{ mA} \\
 \text{(d)} \quad I &= \frac{V}{R} = \frac{30 \text{ V}}{15 \text{ k}\Omega} = 2 \text{ mA} \\
 \text{(e)} \quad I &= \frac{V}{R} = \frac{250 \text{ V}}{5.6 \text{ M}\Omega} = 44.6 \mu\text{A}
 \end{aligned}$$

Chapter 3

16. (a) $I = \frac{V}{R} = \frac{9 \text{ V}}{2.7 \text{ k}\Omega} = \mathbf{3.33 \text{ mA}}$

(b) $I = \frac{V}{R} = \frac{5.5 \text{ V}}{10 \text{ k}\Omega} = \mathbf{550 \mu\text{A}}$

(c) $I = \frac{V}{R} = \frac{40 \text{ V}}{68 \text{ k}\Omega} = \mathbf{588 \mu\text{A}}$

(d) $I = \frac{V}{R} = \frac{1 \text{ kV}}{2.2 \text{ k}\Omega} = \mathbf{455 \text{ mA}}$

(e) $I = \frac{V}{R} = \frac{66 \text{ kV}}{10 \text{ M}\Omega} = \mathbf{6.6 \text{ mA}}$

17. $I = \frac{V}{R} = \frac{12 \text{ V}}{10 \Omega} = \mathbf{1.2 \text{ A}}$

18. $R = 3300 \Omega \pm 5\%$

$$R_{max} = 3300 \Omega + (0.5)(3300 \Omega) = 3465 \Omega$$

$$R_{min} = 3300 \Omega - (0.5)(3300 \Omega) = 3135 \Omega$$

$$I_{max} = \frac{V_s}{R_{min}} = \frac{12 \text{ V}}{3135 \Omega} = \mathbf{3.83 \text{ mA}}$$

$$I_{min} = \frac{V_s}{R_{max}} = \frac{12 \text{ V}}{3465 \Omega} = \mathbf{3.46 \text{ mA}}$$

19. $R = 47 \text{ k}\Omega \pm 10\%$

$$R_{min} = 47 \text{ k}\Omega - 0.1(4.7 \text{ k}\Omega) = 42.3 \text{ k}\Omega$$

$$R_{max} = 47 \text{ k}\Omega + 0.1(4.7 \text{ k}\Omega) = 51.7 \text{ k}\Omega$$

$$I_{min} = \frac{V}{R_{max}} = \frac{25 \text{ V}}{51.7 \text{ k}\Omega} = 484 \mu\text{A}$$

$$I_{max} = \frac{V}{R_{min}} = \frac{25 \text{ V}}{42.3 \text{ k}\Omega} = 591 \mu\text{A}$$

$$I_{nom} = \frac{V}{R} = \frac{25 \text{ V}}{47 \text{ k}\Omega} = \mathbf{532 \mu\text{A}}$$

20. $R = 37.4 \Omega$

$$I = \frac{V}{R} = \frac{12 \text{ V}}{37.4 \Omega} = \mathbf{0.321 \text{ A}}$$

21. $I = 0.642 \text{ A}$

Yes, the current exceeds the 0.5 A rating of the fuse.

22. $V_{R(max)} = 120 \text{ V} - 100 \text{ V} = \mathbf{20 \text{ V}}$

$$I_{max} = \frac{V_{R(max)}}{R_{min}} = \frac{20 \text{ V}}{8 \Omega} = 2.5 \text{ A}$$

A fuse with a rating of less than 2.5 A must be used. A 2-A fuse is suggested.

Section 3-3 Calculating Voltage

23. (a) $V = IR = (2 \text{ A})(18 \Omega) = \mathbf{36 \text{ V}}$
 (b) $V = IR = (5 \text{ A})(56 \Omega) = \mathbf{280 \text{ V}}$
 (c) $V = IR = (2.5 \text{ A})(680 \Omega) = \mathbf{1.7 \text{ kV}}$
 (d) $V = IR = (0.6 \text{ A})(47 \Omega) = \mathbf{28.2 \text{ V}}$
 (e) $V = IR = (0.1 \text{ A})(560 \Omega) = \mathbf{56 \text{ V}}$
24. (a) $V = IR = (1 \text{ mA})(10 \Omega) = \mathbf{10 \text{ mV}}$
 (b) $V = IR = (50 \text{ mA})(33 \Omega) = \mathbf{1.65 \text{ V}}$
 (c) $V = IR = (3 \text{ A})(5.6 \text{ k}\Omega) = \mathbf{16.8 \text{ kV}}$
 (d) $V = IR = (1.6 \text{ mA})(2.2 \text{ k}\Omega) = \mathbf{3.52 \text{ V}}$
 (e) $V = IR = (250 \mu\text{A})(1 \text{ k}\Omega) = \mathbf{250 \text{ mV}}$
 (f) $V = IR = (500 \text{ mA})(1.5 \text{ M}\Omega) = \mathbf{750 \text{ kV}}$
 (g) $V = IR = (850 \mu\text{A})(10 \text{ M}\Omega) = \mathbf{8.5 \text{ kV}}$
 (h) $V = IR = (75 \mu\text{A})(47 \Omega) = \mathbf{3.53 \text{ mV}}$
25. $V_S = IR = (3 \text{ A})(27 \Omega) = \mathbf{81 \text{ V}}$
26. (a) $V = IR = (3 \text{ mA})(27 \text{ k}\Omega) = \mathbf{81 \text{ V}}$
 (b) $V = IR = (5 \mu\text{A})(100 \text{ M}\Omega) = \mathbf{500 \text{ V}}$
 (c) $V = IR = (2.5 \text{ A})(47 \Omega) = \mathbf{117.5 \text{ V}}$
27. Wire resistance $= R_W = \frac{(10.4 \text{ CM} \cdot \Omega/\text{ft})(24 \text{ ft})}{1624.3 \text{ CM}} = 0.154 \Omega$
- (a) $I = \frac{V}{R + R_W} = \frac{6 \text{ V}}{100.154 \Omega} = \mathbf{59.9 \text{ mA}}$
 (b) $V_R = (59.9 \text{ mA})(100 \Omega) = \mathbf{5.99 \text{ V}}$
 (c) $V_{RW} = I \left(\frac{R_W}{2} \right) = (59.9 \text{ mA})(0.154 \Omega/2) = \mathbf{4.61 \text{ mV}}$

Section 3-4 Calculating Resistance

28. (a) $R = \frac{V}{I} = \frac{10 \text{ V}}{2 \text{ A}} = \mathbf{5 \Omega}$
 (b) $R = \frac{V}{I} = \frac{90 \text{ V}}{45 \text{ A}} = \mathbf{2 \Omega}$
 (c) $R = \frac{V}{I} = \frac{50 \text{ V}}{5 \text{ A}} = \mathbf{10 \Omega}$
 (d) $R = \frac{V}{I} = \frac{5.5 \text{ V}}{10 \text{ A}} = \mathbf{550 \text{ m}\Omega}$
 (e) $R = \frac{V}{I} = \frac{150 \text{ V}}{0.5 \text{ A}} = \mathbf{300 \Omega}$

Chapter 3

29. (a) $R = \frac{V}{I} = \frac{10 \text{ kV}}{5 \text{ A}} = 2 \text{ k}\Omega$
(b) $R = \frac{V}{I} = \frac{7 \text{ V}}{2 \text{ mA}} = 3.5 \text{ k}\Omega$
(c) $R = \frac{V}{I} = \frac{500 \text{ V}}{250 \text{ mA}} = 2 \text{ k}\Omega$
(d) $R = \frac{V}{I} = \frac{50 \text{ V}}{500 \mu\text{A}} = 100 \text{ k}\Omega$
(e) $R = \frac{V}{I} = \frac{1 \text{ kV}}{1 \text{ mA}} = 1 \text{ M}\Omega$

30. $R = \frac{V}{I} = \frac{6 \text{ V}}{2 \text{ mA}} = 3 \text{ k}\Omega$

31. (a) $R_{FIL.} = \frac{V}{I} = \frac{120 \text{ V}}{0.8 \text{ A}} = 150 \Omega$

32. Measure the current with an ammeter connected as shown in Figure 3-5, then calculate the unknown resistance as $R = 12 \text{ V}/I$.

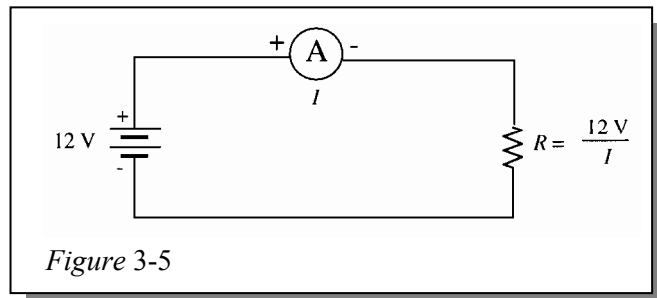

33. $R = \frac{V}{I} = \frac{100 \text{ V}}{750 \text{ mA}} = 133 \Omega$
 $R = \frac{V}{I} = \frac{100 \text{ V}}{1 \text{ A}} = 100 \Omega$

The source can be shorted if the rheostat is set to 0Ω .

34. $R_{\min} + 15 \Omega = \frac{120 \text{ V}}{2 \text{ A}} = 60 \Omega$. Thus $R_{\min} = 60 \Omega - 15 \Omega = 45 \Omega$

The rheostat must actually be set to slightly greater than 45Ω so that the current is limited to slightly less than 2 A .

35. $R_{\min} + 15 \Omega = \frac{110 \text{ V}}{1 \text{ A}} = 110 \Omega$
 $R_{\min} = 110 \Omega - 15 \Omega = 95 \Omega$

Section 3-5 Introduction to Troubleshooting

36. The 4th bulb from the left is open.
37. It should take **five** (maximum) resistance measurements.

Multisim Troubleshooting and Analysis

- 38. R_B is open.
- 39. $R_A = 560\text{ k}\Omega$, $R_B = 2.2\text{ M}\Omega$, $R_C = 1.8\text{ k}\Omega$, $R_D = 33\ \Omega$
- 40. No fault. $I = 1.915\text{ mA}$, $V = 9.00\text{ V}$
- 41. $V = 18\text{ V}$, $I = 5.455\text{ mA}$, $R = 3.3\text{ k}\Omega$
- 42. R is leaky.

Chapter 4

Energy and Power

Note: Solutions show conventional current direction.

Section 4-1 Energy and Power

- volt = joule/coulomb
ampere = coulomb/s
 $VI = (\text{joule/coulomb})(\text{coulomb/s}) = \text{joule/s}$
- 1 kWh = (1000 joules/s)(3600 s) = **3.6×10^6 joules**
- 1 watt = 1 joule/s
 $P = 350 \text{ J/s} = \textbf{350 W}$
- $P = \frac{W}{t} = \frac{7500 \text{ J}}{5 \text{ h}}$
 $\frac{7500 \text{ J}}{(5 \text{ h})(3600 \text{ s/h})} = \frac{7500 \text{ J}}{18000 \text{ s}} = \textbf{417 mW}$
- $P = \frac{1000 \text{ J}}{50 \text{ ms}} = \textbf{20 kW}$
- 1000 W = 1×10^3 W = **1 kW**
 - 3750 W = 3.75×10^3 W = **3.75 kW**
 - 160 W = 0.160×10^3 W = **0.160 kW**
 - 50,000 W = 50×10^3 W = **50 kW**
- 1,000,000 W = 1×10^6 W = **1 MW**
 - 3×10^6 W = **3 MW**
 - 15×10^7 W = 150×10^6 = **150 MW**
 - 8700 kW = 8700×10^3 W = 8.7×10^6 W = **8.7 MW**
- 1 W = 1000×10^{-3} W = **1000 mW**
 - 0.4 W = 400×10^{-3} W = **400 mW**
 - 0.002 W = 2×10^{-3} = **2 mW**
 - 0.0125 W = 12.5×10^{-3} W = **12.5 mW**
- 2 W = **2,000,000 μ W**
 - 0.0005 W = **500 μ W**
 - 0.25 mW = **250 μ W**
 - 0.00667 mW = **6.67 μ W**
- 1.5 kW = 1.5×10^3 W = **1500 W**
 - 0.5 MW = 0.5×10^6 W = **500,000 W**
 - 350 mW = 350×10^{-3} W = **0.350 W**
 - 9000 μ W = 9000×10^{-6} W = **0.009 W**

11. Energy = $W = Pt = (100 \text{ mW})(24 \text{ h})(3600 \text{ s/h}) = 8.64 \times 10^3 \text{ J}$
12. $300 \text{ W} = 0.3 \text{ kW}$
 $(30 \text{ days})(24 \text{ h/day}) = 720 \text{ h}$
 $(0.3 \text{ kW})(720 \text{ h}) = 216 \text{ kWh}$
13. $1500 \text{ kWh}/31 \text{ days} = 48.39 \text{ kWh/day}$
 $(48.39 \text{ kWh/day})/24 \text{ h} = 2.02 \text{ kW/day}$
14. $5 \times 10^6 \text{ watt-minutes} = 5 \times 10^3 \text{ kWminutes}$
 $(5 \times 10^3 \text{ kWmin})(1 \text{ h}/60 \text{ min}) = 83.3 \text{ kWh}$
15. $\frac{6700 \text{ Ws}}{(1000 \text{ W/kW})(3600 \text{ s/h})} = 0.00186 \text{ kWh}$
16. $W = Pt$
 $P = I^2R = (5 \text{ A})^2(47 \Omega) = 1175 \text{ W}$
 $t = \frac{W}{P} = \frac{25 \text{ J}}{1175 \text{ W}} = 0.0213 \text{ s} = 21.3 \text{ ms}$

Section 4-2 Power in an Electric Circuit

17. $R_L = \frac{V}{I} = \frac{75 \text{ V}}{2 \text{ A}} = 37.5 \Omega$
18. $P = VI = (5.5 \text{ V})(3 \text{ mA}) = 16.5 \text{ mW}$
19. $P = VI = (120 \text{ V})(3 \text{ A}) = 360 \text{ W}$
20. $P = I^2R = (500 \text{ mA})^2(4.7 \text{ k}\Omega) = 1.175 \text{ kW}$
21. $P = I^2R = (100 \mu\text{A})^2(10 \text{ k}\Omega) = 100 \mu\text{W}$
22. $P = \frac{V^2}{R} = \frac{(60 \text{ V})^2}{680 \Omega} = 5.29 \text{ W}$
23. $P = \frac{V^2}{R} = \frac{(1.5 \text{ V})^2}{56 \Omega} = 40.2 \text{ mW}$
24. $P = I^2R$
 $R = \frac{P}{I^2} = \frac{100 \text{ W}}{(2 \text{ A})^2} = 25 \Omega$
25. (a) $P = \frac{V^2}{R} = \frac{(12 \text{ V})^2}{10 \Omega} = 14.4 \text{ W}$
 $W = Pt = (14.4 \text{ W})(2 \text{ min})(1/60 \text{ h/min}) = 0.48 \text{ Wh}$
- (b) If the resistor is disconnected after 1 minute, the power during the first minute is equal to the power during the two minute interval. Only energy changes with time.

Chapter 4

Section 4-3 Resistor Power Ratings

26. $P = I^2 R = (10 \text{ mA})^2 (6.8 \text{ k}\Omega) = 0.68 \text{ W}$
Use at least the next highest standard rating of 1 W.
27. Use the 12 W resistor to allow a minimum safety margin of greater than 20%. If the 8 W resistor is used, it will be operating in a marginal condition and its useful life will be reduced.

Section 4-4 Energy Conversion and Voltage Drop in Resistance

28. See Figure 4-1.

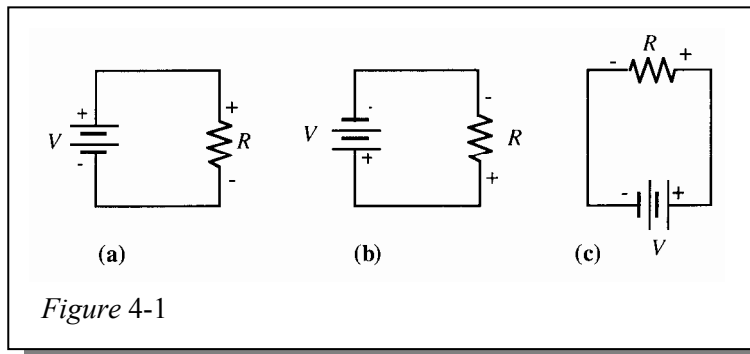

Section 4-5 Power Supplies

29. $V_{\text{OUT}} = \sqrt{P_L R_L} = \sqrt{(1 \text{ W})(50 \Omega)} = 7.07 \text{ V}$
30. $P_{\text{AVG}} = \frac{V^2}{R} = \frac{(1.25)^2 \text{ V}}{10 \Omega} = 156 \text{ mW}$
31. $W = Pt = (0.156 \text{ W})(90 \text{ h}) = (0.156 \text{ W})(324,000 \text{ s}) = 50,544 \text{ J}$
32. Ampere-hour rating = $(1.5 \text{ A})(24 \text{ h}) = 36 \text{ Ah}$
33. $I = \frac{80 \text{ Ah}}{10 \text{ h}} = 8 \text{ A}$
34. $I = \frac{650 \text{ mAh}}{48 \text{ h}} = 13.5 \text{ mA}$
35. $P_{\text{Lost}} = P_{\text{IN}} - P_{\text{OUT}} = 500 \text{ mW} - 400 \text{ mW} = 100 \text{ mW}$
 $\% \text{ efficiency} = \left(\frac{P_{\text{OUT}}}{P_{\text{IN}}} \right) 100\% = \left(\frac{400 \text{ mW}}{500 \text{ mW}} \right) 100\% = 80\%$
36. $P_{\text{OUT}} = (\text{efficiency})P_{\text{IN}} = (0.85)(5 \text{ W}) = 4.25 \text{ W}$

37. Assume that the total consumption of the power supply is the input power plus the power lost.

$$P_{\text{OUT}} = 2 \text{ W}$$

$$\% \text{ efficiency} = \left(\frac{P_{\text{OUT}}}{P_{\text{IN}}} \right) 100\%$$

$$P_{\text{IN}} = \left(\frac{P_{\text{OUT}}}{\% \text{ efficiency}} \right) 100\% = \left(\frac{2 \text{ W}}{60\%} \right) 100\% = 3.33 \text{ W}$$

$$\text{Energy} = W = Pt = (3.33 \text{ W})(24 \text{ h}) = 79.9 \text{ Wh} \cong \mathbf{0.08 \text{ kWh}}$$

Multisim Troubleshooting and Analysis

38. $V = 24 \text{ V}, I = 0.035 \text{ A}, R = 680 \Omega$

39. $V = 5 \text{ V}, I = 5 \text{ mA}, R = 1 \text{ k}\Omega$

40. $I = 833.3 \text{ mA}$

Chapter 5

Series Circuits

Note: Solutions show conventional current direction.

Section 5-1 Resistors in Series

1. See Figure 5-1.

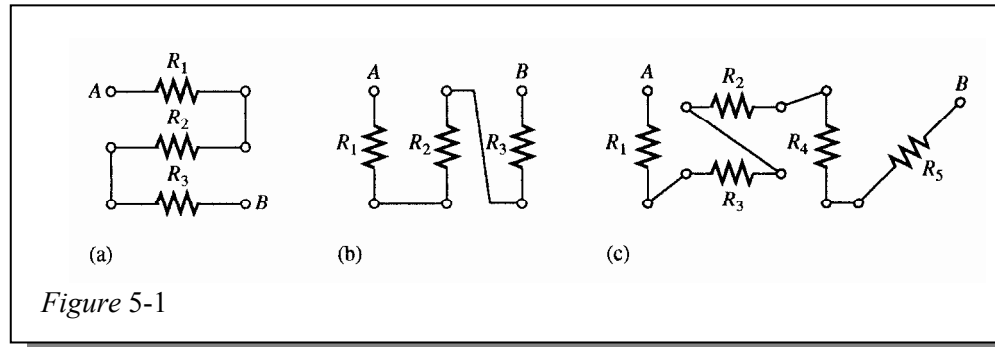

2. $R_1, R_2, R_3, R_4,$ and R_9 are in series (pin 5 to 6).
 R_7, R_{13}, R_{14} and R_{16} are in series (pin 1 to 8).
 $R_6, R_8,$ and R_{12} are in series (pin 2 to 3).
 $R_5, R_{10}, R_{11},$ and R_{15} are in series (pin 4 to 7).
 See Figure 5-2.

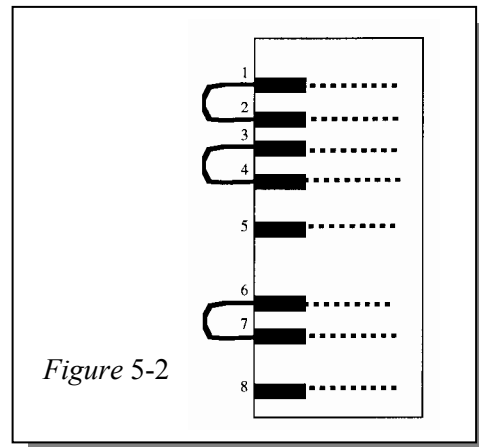

3. $R_{1-8} = R_{13} + R_7 + R_{14} + R_{16}$
 $= 68 \text{ k}\Omega + 33 \text{ k}\Omega + 47 \text{ k}\Omega + 22 \text{ k}\Omega$
 $= 170 \text{ k}\Omega$
4. $R_{2-3} = R_{12} + R_8 + R_6 = 10 \text{ }\Omega + 18 \text{ }\Omega + 22 \text{ }\Omega$
 $= 50 \text{ }\Omega$
5. $R_1, R_7, R_8,$ and R_{10} are in series.
 $R_2, R_4, R_6,$ and R_{11} are in series.
 $R_3, R_5, R_9,$ and R_{12} are in series.

Section 5-2 Current in a Series Circuit

6. $I = \frac{V}{R_T} = \frac{12 \text{ V}}{120 \text{ }\Omega} = 100 \text{ mA}$

7. $I = 5 \text{ mA}$ at all points in the series circuit.

8. See Figure 5-3. The current through R_2 , R_3 , R_4 , and R_9 is also measured by this set-up.

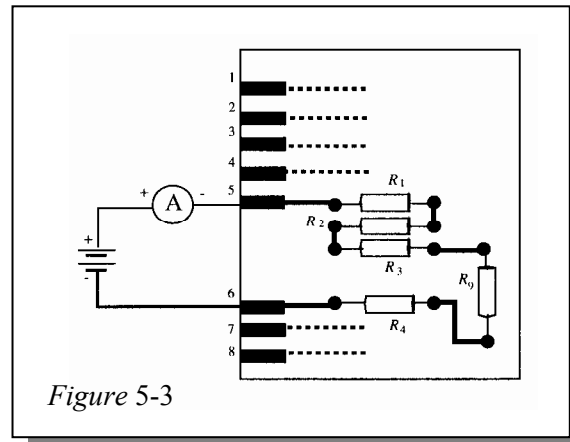

9. See Figure 5-4.

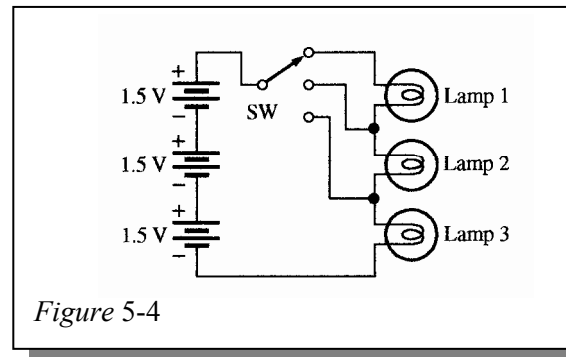

Section 5-3 Total Series Resistance

10. $R_T = 1\ \Omega + 2.2\ \Omega + 5.6\ \Omega + 12\ \Omega + 22\ \Omega = 42.8\ \Omega$
11. (a) $R_T = 560\ \Omega + 1000\ \Omega = 1560\ \Omega$
 (b) $R_T = 47\ \Omega + 56\ \Omega = 103\ \Omega$
 (c) $R_T = 1.5\ \text{k}\Omega + 2.2\ \text{k}\Omega + 10\ \text{k}\Omega = 13.7\ \text{k}\Omega$
 (d) $R_T = 1\ \text{M}\Omega + 470\ \text{k}\Omega + 1\ \text{k}\Omega + 2.2\ \text{M}\Omega = 3.671\ \text{M}\Omega$
12. (a) $R_T = 1\ \text{k}\Omega + 5.6\ \text{k}\Omega + 2.2\ \text{k}\Omega = 8.8\ \text{k}\Omega$
 (b) $R_T = 4.7\ \Omega + 10\ \Omega + 12\ \Omega + 1\ \Omega = 27.7\ \Omega$
 (c) $R_T = 1\ \text{M}\Omega + 560\ \text{k}\Omega + 5.6\ \text{M}\Omega + 680\ \text{k}\Omega + 10\ \text{M}\Omega = 17.84\ \text{M}\Omega$
13. $R_T = 12(5.6\ \text{k}\Omega) = 67.2\ \text{k}\Omega$
14. $R_T = 6(56\ \Omega) + 8(100\ \Omega) + 2(22\ \Omega) = 336\ \Omega + 800\ \Omega + 44\ \Omega = 1180\ \Omega$
15. $R_T = R_1 + R_2 + R_3 + R_4 + R_5$
 $R_5 = R_T - (R_1 + R_2 + R_3 + R_4)$
 $= 17.4\ \text{k}\Omega - (5.6\ \text{k}\Omega + 1\ \text{k}\Omega + 2.2\ \text{k}\Omega + 4.7\ \text{k}\Omega) = 17.4\ \text{k}\Omega - 13.5\ \text{k}\Omega = 3.9\ \text{k}\Omega$

Chapter 5

16. $R_T = 3(5.6 \text{ k}\Omega) + 1 \text{ k}\Omega + 2(100 \text{ }\Omega) = 16.8 \text{ k}\Omega + 1 \text{ k}\Omega + 200 \text{ }\Omega = 18 \text{ k}\Omega$

Three 5.6 k Ω resistors, one 1 k Ω resistor, and two 100 Ω resistors.
Other combinations are possible.

17. $R_T = 1 \text{ k}\Omega + 5.6 \text{ k}\Omega + 2.2 \text{ k}\Omega + 4.7 \text{ }\Omega + 10 \text{ }\Omega + 12 \text{ }\Omega + 1 \text{ }\Omega$
 $+ 1 \text{ M}\Omega + 560 \text{ k}\Omega + 5.6 \text{ M}\Omega + 680 \text{ k}\Omega + 10 \text{ M}\Omega$
 $= 17.848827.7 \text{ M}\Omega \cong \mathbf{17.8 \text{ M}\Omega}$

18. **Position 1:**

$$R_T = R_1 + R_3 + R_5 = 510 \text{ }\Omega + 820 \text{ }\Omega + 680 \text{ }\Omega = \mathbf{2.01 \text{ k}\Omega}$$

Position 2:

$$R_T = R_1 + R_2 + R_3 + R_4 + R_5 = 510 \text{ }\Omega + 910 \text{ }\Omega + 820 \text{ }\Omega + 750 \text{ }\Omega + 680 \text{ }\Omega = \mathbf{3.67 \text{ k}\Omega}$$

Section 5-4 Application of Ohm's Law

19. (a) $R_T = R_1 + R_2 + R_3 = 2.2 \text{ k}\Omega + 5.6 \text{ k}\Omega + 1 \text{ k}\Omega = 8.8 \text{ k}\Omega$

$$I = \frac{V}{R_T} = \frac{5.5 \text{ V}}{8.8 \text{ k}\Omega} = \mathbf{625 \text{ }\mu\text{A}}$$

(b) $R_T = R_1 + R_2 + R_3 = 1 \text{ M}\Omega + 2.2 \text{ M}\Omega + 560 \text{ k}\Omega = 3.76 \text{ M}\Omega$

$$I = \frac{V}{R_T} = \frac{16 \text{ V}}{3.76 \text{ M}\Omega} = \mathbf{4.26 \text{ }\mu\text{A}}$$

20. (a) $I = 625 \text{ }\mu\text{A}$

$$V_1 = IR_1 = (625 \text{ }\mu\text{A})(2.2 \text{ k}\Omega) = \mathbf{1.375 \text{ V}}$$

$$V_2 = IR_2 = (625 \text{ }\mu\text{A})(5.6 \text{ k}\Omega) = \mathbf{3.5 \text{ V}}$$

$$V_3 = IR_3 = (625 \text{ }\mu\text{A})(1 \text{ k}\Omega) = \mathbf{0.625 \text{ V}}$$

(b) $I = 4.26 \text{ }\mu\text{A}$

$$V_1 = IR_1 = (4.26 \text{ }\mu\text{A})(1 \text{ M}\Omega) = \mathbf{4.26 \text{ V}}$$

$$V_2 = IR_2 = (4.26 \text{ }\mu\text{A})(2.2 \text{ M}\Omega) = \mathbf{9.36 \text{ V}}$$

$$V_3 = IR_3 = (4.26 \text{ }\mu\text{A})(560 \text{ k}\Omega) = \mathbf{2.38 \text{ V}}$$

21. $R_T = 3(470 \text{ }\Omega) = 1.41 \text{ k}\Omega$

(a) $I = \frac{V}{R_T} = \frac{48 \text{ V}}{1.41 \text{ k}\Omega} = \mathbf{34 \text{ mA}}$

(b) $V_R = \frac{48 \text{ V}}{3} = \mathbf{16 \text{ V}}$

(c) $P = (34 \text{ mA})^2(470 \text{ }\Omega) = \mathbf{0.543 \text{ W}}$

22. $R_T = \frac{V}{I} = \frac{5 \text{ V}}{2.23 \text{ mA}} = 2.24 \text{ k}\Omega$

$$R_{\text{each}} = \frac{R_T}{4} = \frac{2.24 \text{ k}\Omega}{4} = \mathbf{560 \text{ }\Omega}$$

23. $R_1 = \frac{V_1}{I} = \frac{21.7 \text{ V}}{65.8 \text{ mA}} = \mathbf{330 \Omega}$ $R_2 = \frac{V_2}{I} = \frac{14.5 \text{ V}}{65.8 \text{ mA}} = \mathbf{220 \Omega}$
 $R_1 = \frac{V_3}{I} = \frac{6.58 \text{ V}}{65.8 \text{ mA}} = \mathbf{100 \Omega}$ $R_4 = \frac{V_4}{I} = \frac{30.9 \text{ V}}{65.8 \text{ mA}} = \mathbf{470 \Omega}$
24. $V_1 = IR_1 = (12.3 \text{ mA})(82 \Omega) = \mathbf{1.01 \text{ V}}$
 $R_2 = \frac{V_2}{I} = \frac{12 \text{ V} - 2.21 \text{ V} - 1.01 \text{ V}}{12.3 \text{ mA}} = \mathbf{714 \Omega}$
 $R_3 = \frac{V_3}{I} = \frac{2.21 \text{ V}}{12.3 \text{ mA}} = \mathbf{180 \Omega}$
25. (a) $R_T = R_1 + R_2 + R_3 + R_4$
 $R_4 = \frac{12 \text{ V}}{7.84 \text{ mA}} - (R_1 + R_2 + R_3) = \frac{12 \text{ V}}{7.84 \text{ mA}} - 1200 \Omega = 1531 \Omega - 1200 \Omega = \mathbf{331 \Omega}$
- (b) **Position B:** $I = \frac{12 \text{ V}}{R_2 + R_3 + R_4} = \frac{12 \text{ V}}{1311 \Omega} = \mathbf{9.15 \text{ mA}}$
Position C: $I = \frac{12 \text{ V}}{R_3 + R_4} = \frac{12 \text{ V}}{841 \Omega} = \mathbf{14.3 \text{ mA}}$
Position D: $I = \frac{12 \text{ V}}{R_4} = \frac{12 \text{ V}}{331 \Omega} = \mathbf{36.3 \text{ mA}}$
- (c) No
26. **Position A:**
 $R_T = R_1 = 1 \text{ k}\Omega$
 $I = \frac{V}{R_T} = \frac{9 \text{ V}}{1 \text{ k}\Omega} = \mathbf{9 \text{ mA}}$
- Position B:**
 $R_T = R_1 + R_2 + R_5 = 1 \text{ k}\Omega + 33 \text{ k}\Omega + 22 \text{ k}\Omega = 56 \text{ k}\Omega$
 $I = \frac{V}{R_T} = \frac{9 \text{ V}}{56 \text{ k}\Omega} = \mathbf{161 \mu\text{A}}$
- Position C:**
 $R_T = R_1 + R_2 + R_3 + R_4 + R_5 = 1 \text{ k}\Omega + 33 \text{ k}\Omega + 68 \text{ k}\Omega + 27 \text{ k}\Omega + 22 \text{ k}\Omega = 151 \text{ k}\Omega$
 $I = \frac{V}{R_T} = \frac{9 \text{ V}}{151 \text{ k}\Omega} = \mathbf{59.6 \mu\text{A}}$

Section 5-5 Voltage Sources in Series

27. $V_T = 5 \text{ V} + 9 \text{ V} = \mathbf{14 \text{ V}}$
28. $V_T = 12 \text{ V} - 3 \text{ V} = \mathbf{9 \text{ V}}$
29. (a) $V_T = 10 \text{ V} + 8 \text{ V} + 5 \text{ V} = \mathbf{23 \text{ V}}$
(b) $V_T = 50 \text{ V} + 10 \text{ V} - 25 \text{ V} = \mathbf{35 \text{ V}}$
(c) $V_T = 8 \text{ V} - 8 \text{ V} = \mathbf{0 \text{ V}}$

Chapter 5

Section 5-6 Kirchhoff's Voltage Law

30. $V_S = 5.5 \text{ V} + 8.2 \text{ V} + 12.3 \text{ V} = 26 \text{ V}$

31. $V_S = V_1 + V_2 + V_3 + V_4 + V_5$
 $20 \text{ V} = 1.5 \text{ V} + 5.5 \text{ V} + 3 \text{ V} + 6 \text{ V} + V_5$
 $V_5 = 20 \text{ V} - (1.5 \text{ V} + 5.5 \text{ V} + 3 \text{ V} + 6 \text{ V}) = 20 \text{ V} - 16 \text{ V} = 4 \text{ V}$

32. (a) By Kirchhoff's voltage law:
 $15 \text{ V} = 2 \text{ V} + V_2 + 3.2 \text{ V} + 1 \text{ V} + 1.5 \text{ V} + 0.5 \text{ V}$
 $V_2 = 15 \text{ V} - (2 \text{ V} + 3.2 \text{ V} + 1 \text{ V} + 1.5 \text{ V} + 0.5 \text{ V}) = 15 \text{ V} - 8.2 \text{ V} = 6.8 \text{ V}$
(b) $V_R = 8 \text{ V}$, $V_{2R} = 2(8 \text{ V}) = 16 \text{ V}$, $V_{3R} = 3(8 \text{ V}) = 24 \text{ V}$, $V_{4R} = 4(8 \text{ V}) = 32 \text{ V}$
 $V_S = V_R + V_{2R} + V_{3R} + V_{4R} = 11(V_R) = 88 \text{ V}$

33. $I = \frac{11.2 \text{ V}}{56 \Omega} = 200 \text{ mA}$

$$R_4 = \frac{4.4 \text{ V}}{200 \text{ mA}} = 22 \Omega$$

34. $R_1 = \frac{V_1}{I} = \frac{5.6 \text{ V}}{10 \text{ mA}} = 560 \Omega$

$$R_2 = \frac{P_2}{I^2} = \frac{22 \text{ mW}}{(10 \text{ mA})^2} = 220 \Omega$$

$$R_T = \frac{9 \text{ V}}{10 \text{ mA}} = 900 \Omega$$

$$R_3 = R_T - R_1 - R_2 = 900 \Omega - 560 \Omega - 200 \Omega = 120 \Omega$$

35. **Position A:**

$$R_T = R_1 + R_2 + R_3 + R_4 = 1.8 \text{ k}\Omega + 1 \text{ k}\Omega + 820 \Omega + 560 \Omega = 4.18 \text{ k}\Omega$$

Voltage drop across R_1 through R_4 :

$$V = IR_T = (3.35 \text{ mA})(4.18 \text{ k}\Omega) = 14 \text{ V}$$

$$V_5 = 18 \text{ V} - 14 \text{ V} = 4 \text{ V}$$

Position B:

$$R_T = R_1 + R_2 + R_3 = 1.8 \text{ k}\Omega + 1 \text{ k}\Omega + 820 \Omega = 3.62 \text{ k}\Omega$$

Voltage drop across R_1 through R_3 :

$$V = IR_T = (3.73 \text{ mA})(3.62 \text{ k}\Omega) = 13.5 \text{ V}$$

$$V_5 = 18 \text{ V} - 13.5 \text{ V} = 4.5 \text{ V}$$

Position C:

$$R_T = R_1 + R_2 = 1.8 \text{ k}\Omega + 1 \text{ k}\Omega = 2.8 \text{ k}\Omega$$

Voltage drop across R_1 and R_2 :

$$V = IR_T = (4.5 \text{ mA})(2.8 \text{ k}\Omega) = 12.6 \text{ V}$$

$$V_5 = 18 \text{ V} - 12.6 \text{ V} = 5.4 \text{ V}$$

Position D:

$$R_T = R_1 = 1.8 \text{ k}\Omega$$

Voltage drop across R_1 :

$$V = IR_T = (6 \text{ mA})(1.8 \text{ k}\Omega) = 10.8 \text{ V}$$

$$V_5 = 18 \text{ V} - 10.8 \text{ V} = 7.2 \text{ V}$$

36. Position A:

$$V_1 = (3.35 \text{ mA})(1.8 \text{ k}\Omega) = \mathbf{6.03 \text{ V}}$$

$$V_2 = (3.35 \text{ mA})(1 \text{ k}\Omega) = \mathbf{3.35 \text{ V}}$$

$$V_3 = (3.35 \text{ mA})(820 \Omega) = \mathbf{2.75 \text{ V}}$$

$$V_4 = (3.35 \text{ mA})(560 \Omega) = \mathbf{1.88 \text{ V}}$$

$$V_5 = \mathbf{4.0 \text{ V}}$$

Position B:

$$V_1 = (3.73 \text{ mA})(1.8 \text{ k}\Omega) = \mathbf{6.71 \text{ V}}$$

$$V_2 = (3.73 \text{ mA})(1 \text{ k}\Omega) = \mathbf{3.73 \text{ V}}$$

$$V_3 = (3.73 \text{ mA})(820 \Omega) = \mathbf{3.06 \text{ V}}$$

$$V_5 = \mathbf{4.5 \text{ V}}$$

Position C:

$$V_1 = (4.5 \text{ mA})(1.8 \text{ k}\Omega) = \mathbf{8.1 \text{ V}}$$

$$V_2 = (4.5 \text{ mA})(1 \text{ k}\Omega) = \mathbf{4.5 \text{ V}}$$

$$V_5 = \mathbf{5.4 \text{ V}}$$

Position D:

$$V_1 = (6 \text{ mA})(1.8 \text{ k}\Omega) = \mathbf{10.8 \text{ V}}$$

$$V_5 = \mathbf{7.2 \text{ V}}$$

Section 5-7 Voltage Dividers

$$37. \quad \frac{V_{27}}{V_T} = \left(\frac{27 \Omega}{560 \Omega} \right) 100 = \mathbf{4.82\%}$$

$$38. \quad (a) \quad V_{AB} = \left(\frac{56 \Omega}{156 \Omega} \right) 12 \text{ V} = \mathbf{4.31 \text{ V}}$$

$$(b) \quad V_{AB} = \left(\frac{5.5 \text{ k}\Omega}{6.5 \text{ k}\Omega} \right) 8 \text{ V} = \mathbf{6.77 \text{ V}}$$

$$39. \quad V_A = V_S = \mathbf{15 \text{ V}}$$

$$V_B = \left(\frac{R_2 + R_3}{R_1 + R_2 + R_3} \right) V_S = \left(\frac{13.3 \text{ k}\Omega}{18.9 \text{ k}\Omega} \right) 15 \text{ V} = \mathbf{10.6 \text{ V}}$$

$$V_C = \left(\frac{R_3}{R_1 + R_2 + R_3} \right) V_S = \left(\frac{3.3 \text{ k}\Omega}{18.9 \text{ k}\Omega} \right) 15 \text{ V} = \mathbf{2.62 \text{ V}}$$

$$40. \quad V_{\text{OUT}(\min)} = \left(\frac{R_3}{R_1 + R_2 + R_3} \right) V_S = \left(\frac{680 \Omega}{2150 \Omega} \right) 12 \text{ V} = \mathbf{3.80 \text{ V}}$$

$$V_{\text{OUT}(\max)} = \left(\frac{R_2 + R_3}{R_1 + R_2 + R_3} \right) V_S = \left(\frac{1680 \Omega}{2150 \Omega} \right) 12 \text{ V} = \mathbf{9.38 \text{ V}}$$

Chapter 5

41. $R_T = 15R$

$$V_R = \left(\frac{R}{15R} \right) 90 \text{ V} = \mathbf{6 \text{ V}}$$

$$V_{2R} = \left(\frac{2R}{15R} \right) 90 \text{ V} = \mathbf{12 \text{ V}}$$

$$V_{3R} = \left(\frac{3R}{15R} \right) 90 \text{ V} = \mathbf{18 \text{ V}}$$

$$V_{4R} = \left(\frac{4R}{15R} \right) 90 \text{ V} = \mathbf{24 \text{ V}}$$

$$V_{5R} = \left(\frac{5R}{15R} \right) 90 \text{ V} = \mathbf{30 \text{ V}}$$

42. $V_{AF} = 100 \text{ V}$

$$V_{BF} = \left(\frac{R_{BF}}{R_{AF}} \right) V_{AF} = \left(\frac{86.6 \text{ k}\Omega}{108.6 \text{ k}\Omega} \right) 100 \text{ V} = \mathbf{79.7 \text{ V}}$$

$$V_{CF} = \left(\frac{R_{CF}}{R_{AF}} \right) V_{AF} = \left(\frac{76.6 \text{ k}\Omega}{108.6 \text{ k}\Omega} \right) 100 \text{ V} = \mathbf{70.5 \text{ V}}$$

$$V_{DF} = \left(\frac{R_{DF}}{R_{AF}} \right) V_{AF} = \left(\frac{20.6 \text{ k}\Omega}{108.6 \text{ k}\Omega} \right) 100 \text{ V} = \mathbf{19.0 \text{ V}}$$

$$V_{EF} = \left(\frac{R_{EF}}{R_{AF}} \right) V_{AF} = \left(\frac{5.6 \text{ k}\Omega}{108.6 \text{ k}\Omega} \right) 100 \text{ V} = \mathbf{5.16 \text{ V}}$$

43. $I = \frac{V_1}{R_1} = \frac{10 \text{ V}}{5.6 \text{ k}\Omega} = 1.79 \text{ mA}$

$$V_2 = IR_2 = (1.79 \text{ mA})(1 \text{ k}\Omega) = \mathbf{1.79 \text{ V}}$$

$$V_3 = IR_3 = (1.79 \text{ mA})(560 \Omega) = \mathbf{1.0 \text{ V}}$$

$$V_4 = IR_4 = (1.79 \text{ mA})(10 \text{ k}\Omega) = \mathbf{17.9 \text{ V}}$$

44. See Figure 5-5 for one possible solution:

$$R_T = 18 \text{ k}\Omega + 33 \text{ k}\Omega + 22 \text{ k}\Omega + 27 \text{ k}\Omega = 100 \text{ k}\Omega$$

$$I_T = \frac{30 \text{ V}}{100 \text{ k}\Omega} = 300 \mu\text{A}$$

$$V_A = \left(\frac{82 \text{ k}\Omega}{100 \text{ k}\Omega} \right) 30 \text{ V} = 24.6 \text{ V}$$

$$V_B = \left(\frac{49 \text{ k}\Omega}{100 \text{ k}\Omega} \right) 30 \text{ V} = 14.7 \text{ V}$$

$$V_C = \left(\frac{27 \text{ k}\Omega}{100 \text{ k}\Omega} \right) 30 \text{ V} = 8.1 \text{ V}$$

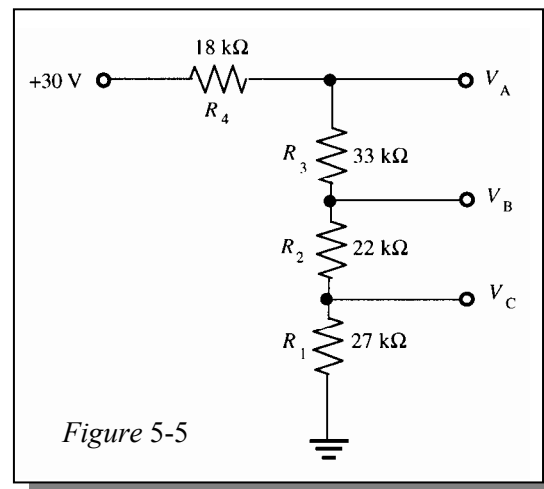

Figure 5-5

$$P_1 = I_T^2 R_1 = (300 \mu\text{A})^2 27 \text{ k}\Omega = 2.43 \text{ mW}$$

$$P_2 = I_T^2 R_2 = (300 \mu\text{A})^2 22 \text{ k}\Omega = 1.98 \text{ mW}$$

$$P_3 = I_T^2 R_3 = (300 \mu\text{A})^2 33 \text{ k}\Omega = 2.97 \text{ mW}$$

$$P_4 = I_T^2 R_4 = (300 \mu\text{A})^2 18 \text{ k}\Omega = 1.62 \text{ mW}$$

All resistors can be 1/8 W.

45. See Figure 5-6 for one possible solution.

$$R_T = 12.1 \text{ k}\Omega$$

$$V_{\text{OUT(max)}} = \left(\frac{10.1 \text{ k}\Omega}{12.1 \text{ k}\Omega} \right) 120 \text{ V} = 100.2 \text{ V}$$

$$V_{\text{OUT(min)}} = \left(\frac{1 \text{ k}\Omega}{12.1 \text{ k}\Omega} \right) 120 \text{ V} = 9.92 \text{ V}$$

These values are within $\pm 1\%$ of the specified values.

$$I_{\text{MAX}} = \frac{120 \text{ V}}{R_T} = \frac{120 \text{ V}}{12.1 \text{ k}\Omega} = 9.9 \text{ mA}$$

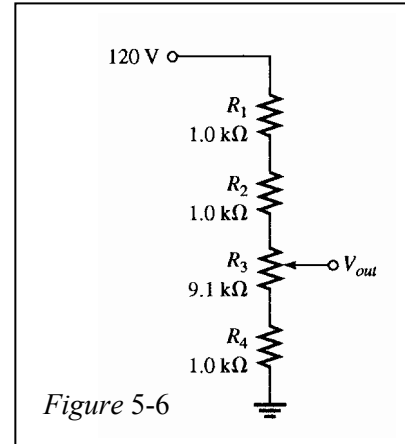

Figure 5-6

Section 5-8 Power in Series Circuits

46. $P_T = 5(50 \text{ mW}) = 250 \text{ mW}$

47. $V_T = V_1 + V_2 + V_3 + V_4 = 10 \text{ V} + 1.79 \text{ V} + 1 \text{ V} + 17.9 \text{ V} = 30.69 \text{ V}$

$$P_T = V_T I = (30.69 \text{ V})(1.79 \text{ mA}) = 54.9 \text{ mW}$$

48. Since $P = I^2 R$ and since each resistor has the same current, the 5.6 kΩ resistor is the limiting element in terms of power dissipation.

$$I_{\text{max}} = \sqrt{\frac{P_{\text{max}}}{R}} = \sqrt{\frac{0.25 \text{ W}}{5.6 \text{ k}\Omega}} = 6.68 \text{ mA}$$

$$V_{5.6 \text{ k}\Omega} = (6.68 \text{ mA})(5.6 \text{ k}\Omega) = 37.4 \text{ V}$$

$$V_{1.2 \text{ k}\Omega} = (6.68 \text{ mA})(1.2 \text{ k}\Omega) = 8.02 \text{ V}$$

$$V_{2.2 \text{ k}\Omega} = (6.68 \text{ mA})(2.2 \text{ k}\Omega) = 14.7 \text{ V}$$

$$V_{3.9 \text{ k}\Omega} = (6.68 \text{ mA})(3.9 \text{ k}\Omega) = 26.1 \text{ V}$$

$$V_{T(\text{max})} = 37.4 \text{ V} + 8.02 \text{ V} + 14.7 \text{ V} + 26.1 \text{ V} = 86.2 \text{ V}$$

49. $I = \frac{V_1}{R_1} = \frac{12 \text{ V}}{5.6 \text{ M}\Omega} = 2.14 \mu\text{A}$

$$R_2 = \frac{V_2}{I} = \frac{4.8 \text{ V}}{2.14 \mu\text{A}} = 2.2 \text{ M}\Omega$$

$$P_3 = I^2 R_3$$

$$R_3 = \frac{P_3}{I^2} = \frac{21.5 \mu\text{W}}{(2.14 \mu\text{A})^2} = 4.7 \text{ M}\Omega$$

$$R_T = R_1 + R_2 + R_3 = 5.6 \text{ M}\Omega + 2.2 \text{ M}\Omega + 4.7 \text{ M}\Omega = 12.5 \text{ M}\Omega$$

Chapter 5

50. (a) $P = I^2 R$
 $R = \frac{P}{I^2}$
 $R_1 + R_2 + R_3 = 2400 \Omega$
 $\frac{\left(\frac{1}{8} \text{ W}\right)}{I^2} + \frac{\left(\frac{1}{4} \text{ W}\right)}{I^2} + \frac{\left(\frac{1}{2} \text{ W}\right)}{I^2} = 2400 \Omega$
 $\frac{\left(\frac{7}{8} \text{ W}\right)}{I^2} = 2400 \Omega$
 $I^2 = \frac{\left(\frac{7}{8} \text{ W}\right)}{2400 \Omega} = 0.0003646 \text{ A}^2$
 $I = \sqrt{0.0003646 \text{ A}^2} = \mathbf{19.1 \text{ mA}}$
- (b) $V_T = IR_T = (19.1 \text{ mA})(2400 \Omega) = \mathbf{45.8 \text{ V}}$
- (c) $R_1 = \frac{P_1}{I^2} = \frac{0.125 \text{ W}}{(19.1 \text{ mA})^2} = \mathbf{343 \Omega}$
 $R_2 = \frac{P_2}{I^2} = \frac{0.25 \text{ W}}{(19.1 \text{ mA})^2} = \mathbf{686 \Omega}$
 $R_3 = \frac{P_3}{I^2} = \frac{0.5 \text{ W}}{(19.1 \text{ mA})^2} = \mathbf{1.37 \text{ k}\Omega}$

Section 5-9 Voltage Measurements

51. $V_{AG} = 100 \text{ V}$ (voltage from point A to ground)
Resistance between A and C :
 $R_{AC} = 5.6 \text{ k}\Omega + 5.6 \text{ k}\Omega = 11.2 \text{ k}\Omega$
Resistance between C and ground:
 $R_{CG} = 1 \text{ k}\Omega + 1 \text{ k}\Omega = 2 \text{ k}\Omega$
 $V_{CG} = \left(\frac{2 \text{ k}\Omega}{13.2 \text{ k}\Omega}\right) 100 \text{ V} = \mathbf{15.2 \text{ V}}$
 $V_{DG} = \left(\frac{1 \text{ k}\Omega}{2 \text{ k}\Omega}\right) V_{CG} = \left(\frac{1 \text{ k}\Omega}{2 \text{ k}\Omega}\right) 15.2 \text{ V} = \mathbf{7.58 \text{ V}}$
 $V_{AC} = \left(\frac{11.2 \text{ k}\Omega}{13.2 \text{ k}\Omega}\right) 100 \text{ V} = 84.9 \text{ V}$
 $V_{BC} = \left(\frac{5.6 \text{ k}\Omega}{11.2 \text{ k}\Omega}\right) V_{AC} = \left(\frac{5.6 \text{ k}\Omega}{11.2 \text{ k}\Omega}\right) 84.9 \text{ V} = 42.5 \text{ V}$
 $V_{BG} = V_{CG} + V_{BC} = 15.2 \text{ V} + 42.5 \text{ V} = \mathbf{57.7 \text{ V}}$

52. Measure the voltage at point A with respect to ground and the voltage at point B with respect to ground. The difference is V_{R2} .

$$V_{R2} = V_B - V_A$$

53. $R_T = R_1 + R_2 + R_3 + R_4 + R_5 = 56 \text{ k}\Omega + 560 \text{ k}\Omega + 100 \text{ k}\Omega + 1 \text{ M}\Omega + 100 \text{ k}\Omega = 1.816 \text{ M}\Omega$

$$V_T = 15 \text{ V} - 9 \text{ V} = 6 \text{ V}$$

$$I = \frac{V_T}{R_T} = \frac{6 \text{ V}}{1.816 \text{ M}\Omega} = 3.3 \text{ }\mu\text{A}$$

$$V_1 = IR_1 = (3.3 \text{ }\mu\text{A})(56 \text{ k}\Omega) = 185 \text{ mV}$$

$$V_A = 15 \text{ V} - V_1 = 15 \text{ V} - 185 \text{ mV} = \mathbf{14.82 \text{ V}}$$

$$V_2 = IR_2 = (3.3 \text{ }\mu\text{A})(560 \text{ k}\Omega) = 1.85 \text{ V}$$

$$V_B = V_A - V_2 = 14.82 \text{ V} - 1.85 \text{ V} = \mathbf{12.97 \text{ V}}$$

$$V_3 = IR_3 = (3.3 \text{ }\mu\text{A})(100 \text{ k}\Omega) = 330 \text{ mV}$$

$$V_C = V_B - V_3 = 12.97 \text{ V} - 330 \text{ mV} = \mathbf{12.64 \text{ V}}$$

$$V_4 = IR_4 = (3.3 \text{ }\mu\text{A})(1 \text{ M}\Omega) = 3.3 \text{ V}$$

$$V_D = V_C - V_4 = 12.64 \text{ V} - 3.3 \text{ V} = \mathbf{9.34 \text{ V}}$$

Section 5-10 Troubleshooting

54. There is no current through the resistors which have zero volts across them; thus, there is an open in the circuit. Since R_2 has voltage across it, it is the open resistor. 12 V will be measured across R_2 .

55. (a) Zero current indicates an open. R_4 is open since all the voltage is dropped across it.

(b)
$$\frac{V_S}{R_1 + R_2 + R_3} = \frac{10 \text{ V}}{300 \text{ }\Omega} = 33.3 \text{ mA}$$

R_4 and R_5 have no effect on the current.

There is a short from A to B , shorting out R_4 and R_5 .

56. $R_2 = 0 \text{ }\Omega$

$$R_T = R_1 + R_3 + R_4 + R_5 = 400 \text{ }\Omega$$

$$I_T = \frac{V_S}{R_T} = \frac{10 \text{ V}}{400 \text{ }\Omega} = \mathbf{25 \text{ mA}}$$

57. The results in Table 5-1 are correct.

Chapter 5

58. If $15\text{ k}\Omega$ is measured between pins 5 and 6, R_3 and R_5 are shorted as indicated in Figure 5-7.
59. In this case, there is a short between the points indicated in Figure 5-7.

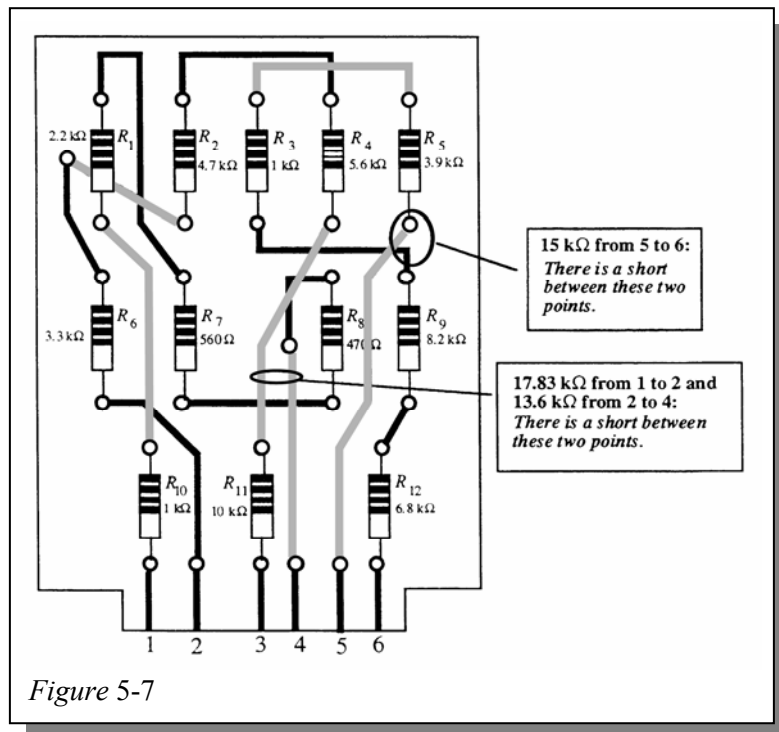

60. (a) R_{11} has burned out because it has the highest resistance value ($P = I^2R$).
- (b) Replace R_{11} ($10\text{ k}\Omega$).
- (c) $R_T = 47.73\text{ k}\Omega$

$$I_{\max} = \sqrt{\frac{P_{11}}{R_{11}}} = \sqrt{\frac{0.5\text{ W}}{10\text{ k}\Omega}} = 7.07\text{ mA}$$

$$V_{\max} = I_{\max}R_T = (7.07\text{ mA})(10\text{ k}\Omega) = 70.7\text{ V}$$

Multisim Troubleshooting and Analysis

61. $7.481\text{ k}\Omega$
62. R_2 is open.
63. $R_3 = 22\ \Omega$
64. 6 V
65. R_1 is shorted.

Chapter 6

Parallel Circuits

Note: Solutions show conventional current direction.

Section 6-1 Resistors in Parallel

1. See Figure 6-1.

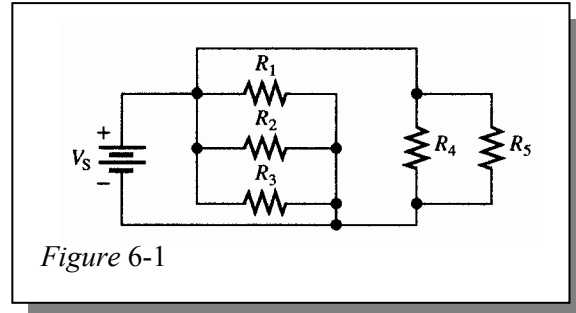

Figure 6-1

2. R_1 , R_2 and R_5 are not individually in parallel with the other resistors. The series combination of R_1 , R_2 , and R_5 is in parallel with the other resistors.
3. R_1 , R_2 , R_5 , R_9 , R_{10} and R_{12} are in parallel.
 R_4 , R_6 , R_7 , and R_8 are in parallel.
 R_3 and R_{11} are in parallel.

Section 6-2 Voltage in a Parallel Circuit

4. $V_1 = V_2 = V_3 = V_4 = 12 \text{ V}$

$$I_T = \frac{V_T}{R_T} = \frac{12 \text{ V}}{550 \Omega} = 21.8 \text{ mA}$$

The total current divides equally among the four equal parallel resistors.

$$I_1 = I_2 = I_3 = I_4 = \frac{21.8 \text{ mA}}{4} = 5.45 \text{ mA}$$
5. The resistors are all in parallel across the source. The voltmeters each measure the voltage across a resistor, so each meter indicates 100 V.
6. **Position A:** $R_T = R_1 \parallel R_4 = (1.0 \text{ k}\Omega) \parallel (2.7 \text{ k}\Omega) = 730 \Omega$
Position B: $R_T = R_1 \parallel R_3 = (1.0 \text{ k}\Omega) \parallel (2.2 \text{ k}\Omega) = 688 \Omega$
Position C: $R_T = R_1 \parallel R_2 = (1.0 \text{ k}\Omega) \parallel (1.8 \text{ k}\Omega) = 643 \Omega$
7. **Position A:**
 $V_1 = 15 \text{ V}$, $V_2 = 0 \text{ V}$, $V_3 = 0 \text{ V}$, $V_4 = 15 \text{ V}$
Position B:
 $V_1 = 15 \text{ V}$, $V_2 = 0 \text{ V}$, $V_3 = 15 \text{ V}$, $V_4 = 0 \text{ V}$
Position C:
 $V_1 = 15 \text{ V}$, $V_2 = 15 \text{ V}$, $V_3 = 0 \text{ V}$, $V_4 = 0 \text{ V}$

Chapter 6

8. **Position A:** $I_T = \frac{15\text{ V}}{730\ \Omega} = 20.6\ \text{mA}$
Position B: $I_T = \frac{15\text{ V}}{688\ \Omega} = 21.8\ \text{mA}$
Position C: $I_T = \frac{15\text{ V}}{643\ \Omega} = 23.3\ \text{mA}$

Section 6-3 Kirchhoff's Current Law

9. $I_T = 250\ \text{mA} + 300\ \text{mA} + 800\ \text{mA} = 1350\ \text{mA} = 1.35\ \text{A}$
10. $I_T = I_1 + I_2 + I_3 + I_4 + I_5$
 $I_5 = I_T - (I_1 + I_2 + I_3 + I_4)$
 $= 500\ \text{mA} - (50\ \text{mA} + 150\ \text{mA} + 25\ \text{mA} + 100\ \text{mA}) = 500\ \text{mA} - 325\ \text{mA} = 175\ \text{mA}$
11. $V_S = I_1 R_1 = (1\ \text{mA})(47\ \Omega) = 47\ \text{mV}$
 $R_2 = \frac{V_S}{I_2} = \frac{47\ \text{mV}}{2.14\ \text{mA}} = 22\ \Omega$
 $R_3 = \frac{V_S}{I_3} = \frac{47\ \text{mV}}{0.47\ \text{mA}} = 100\ \Omega$
 $I_4 = I_T - (I_1 + I_2 + I_3) = 5.03\ \text{mA} - 3.61\ \text{mA} = 1.42\ \text{mA}$
 $R_4 = \frac{V_S}{I_4} = \frac{47\ \text{mV}}{1.42\ \text{mA}} = 33\ \Omega$
12. $I_T = 1.25\ \text{A} + 0.833\ \text{A} + 0.833\ \text{A} + 10\ \text{A} = 12.92\ \text{A}$
 $I_4 = 15\ \text{A} - 12.92\ \text{A} = 2.08\ \text{A}$
See Figure 6-2.

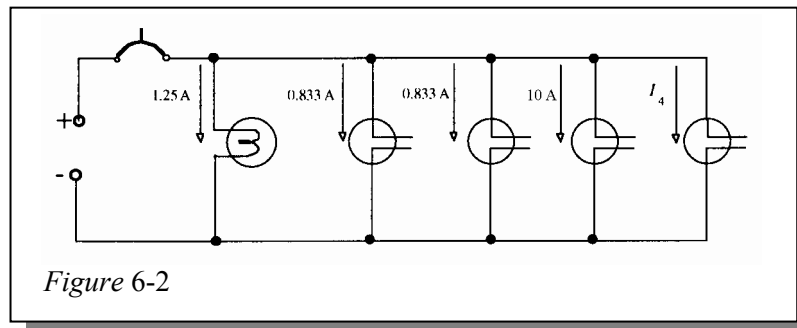

Figure 6-2

13. $V_T = I_T R_T = (100\ \text{mA})(25\ \Omega) = 2500\ \text{mV} = 2.5\ \text{V}$
 $I_{220\ \Omega} = \frac{V_T}{220\ \Omega} = \frac{2.5\ \text{V}}{220\ \Omega} = 11.4\ \text{mA}$

Section 6-4 Total Parallel Resistance

$$14. \quad R_T = \frac{1}{\frac{1}{1 \text{ M}\Omega} + \frac{1}{2.2 \text{ M}\Omega} + \frac{1}{5.6 \text{ M}\Omega} + \frac{1}{12 \text{ M}\Omega} + \frac{1}{22 \text{ M}\Omega}} = 568 \text{ k}\Omega$$

$$15. \quad (a) \quad R_T = \frac{(560 \text{ }\Omega)(1 \text{ k}\Omega)}{560 \text{ }\Omega + 1 \text{ k}\Omega} = 359 \text{ }\Omega$$

$$(b) \quad R_T = \frac{(47 \text{ }\Omega)(56 \text{ }\Omega)}{47 \text{ }\Omega + 56 \text{ }\Omega} = 25.6 \text{ }\Omega$$

$$(c) \quad R_T = \frac{1}{\frac{1}{1.5 \text{ k}\Omega} + \frac{1}{2.2 \text{ k}\Omega} + \frac{1}{10 \text{ k}\Omega}} = 819 \text{ }\Omega$$

$$(d) \quad R_T = \frac{1}{\frac{1}{1 \text{ M}\Omega} + \frac{1}{470 \text{ k}\Omega} + \frac{1}{1 \text{ k}\Omega} + \frac{1}{2.7 \text{ M}\Omega}} = 997 \text{ }\Omega$$

$$16. \quad (a) \quad R_T = \frac{(560 \text{ }\Omega)(220 \text{ }\Omega)}{560 \text{ }\Omega + 220 \text{ }\Omega} = 158 \text{ }\Omega$$

$$(b) \quad R_T = \frac{(27 \text{ k}\Omega)(56 \text{ k}\Omega)}{27 \text{ k}\Omega + 56 \text{ k}\Omega} = 18.2 \text{ k}\Omega$$

$$(c) \quad R_T = \frac{(1.5 \text{ k}\Omega)(2.2 \text{ k}\Omega)}{1.5 \text{ k}\Omega + 2.2 \text{ k}\Omega} = 892 \text{ }\Omega$$

$$17. \quad R_T = \frac{6.8 \text{ k}\Omega}{12} = 0.567 \text{ k}\Omega = 567 \text{ }\Omega$$

18. **Five 470 Ω resistors in parallel:**

$$R_1 = \frac{470 \text{ }\Omega}{5} = 94 \text{ }\Omega$$

Ten 1000 Ω resistors in parallel:

$$R_2 = \frac{1000 \text{ }\Omega}{10} = 100 \text{ }\Omega$$

Two 100 Ω resistors in parallel:

$$R_3 = \frac{100 \text{ }\Omega}{2} = 50 \text{ }\Omega$$

$$19. \quad R_T = \frac{1}{\frac{1}{94 \text{ }\Omega} + \frac{1}{100 \text{ }\Omega} + \frac{1}{50 \text{ }\Omega}} = 24.6 \text{ }\Omega$$

Chapter 6

20. $R_T = \frac{R_1 R_2}{R_1 + R_2}$
 $R_T(R_1 + R_2) = R_1 R_2$
 $R_T R_1 + R_T R_2 = R_1 R_2$
 $R_T R_1 = R_1 R_2 - R_T R_2$
 $R_T R_1 = R_2(R_1 - R_T)$
 $R_2 = \frac{R_T R_1}{R_1 - R_T} = \frac{(389.2 \Omega)(680 \Omega)}{680 \Omega - 389.2 \Omega} = \mathbf{910 \Omega}$
21. (a) $R_T = R_1 = \mathbf{510 \text{ k}\Omega}$
- (b) $R_T = R_1 \parallel R_2 = \frac{1}{\frac{1}{510 \text{ k}\Omega} + \frac{1}{470 \text{ k}\Omega}} = \mathbf{245 \text{ k}\Omega}$
- (c) $R_T = R_1 = \mathbf{510 \text{ k}\Omega}$
 $R_T = R_1 \parallel R_2 \parallel R_3 = \frac{1}{\frac{1}{510 \text{ k}\Omega} + \frac{1}{470 \text{ k}\Omega} + \frac{1}{910 \text{ k}\Omega}} = \mathbf{193 \text{ k}\Omega}$

Section 6-5 Application of Ohm's Law

22. (a) $R_T = \frac{1}{\frac{1}{33 \Omega} + \frac{1}{33 \Omega} + \frac{1}{27 \Omega}} = 10.2 \Omega$
 $I_T = \frac{V}{R_T} = \frac{10 \text{ V}}{10.2 \Omega} = \mathbf{980 \text{ mA}}$
- (b) $R_T = \frac{1}{\frac{1}{1 \text{ k}\Omega} + \frac{1}{4.7 \text{ k}\Omega} + \frac{1}{560 \Omega}} = 334 \Omega$
 $I_T = \frac{V}{R_T} = \frac{25 \text{ V}}{334 \Omega} = \mathbf{74.9 \text{ mA}}$
23. $R_T = \frac{R}{3} = \frac{33 \Omega}{3} = 11 \Omega$
 $I_T = \frac{110 \text{ V}}{11 \Omega} = \mathbf{10 \text{ A}}$
24. $R_T = \frac{V_S}{I_T} = \frac{5 \text{ V}}{1.11 \text{ mA}} = 4.5 \text{ k}\Omega$
 $R_{\text{each}} = 4R_T = 4(4.5 \text{ k}\Omega) = \mathbf{18 \text{ k}\Omega}$
25. $I = \frac{V_S}{R_{\text{filament}}} = \frac{110 \text{ V}}{2.2 \text{ k}\Omega} = \mathbf{50 \text{ mA}}$

When one bulb burns out, the others remain on.

26. (a) $I_2 = I_T - I_1 = 150 \text{ mA} - 100 \text{ mA} = \mathbf{50 \text{ mA}}$

$$R_1 = \frac{10 \text{ V}}{100 \text{ mA}} = \mathbf{100 \Omega}$$

$$R_2 = \frac{10 \text{ V}}{50 \text{ mA}} = \mathbf{200 \Omega}$$

(b) $I_3 = \frac{100 \text{ V}}{1 \text{ k}\Omega} = \mathbf{100 \text{ mA}}$

$$I_2 = \frac{100 \text{ V}}{680 \Omega} = \mathbf{147 \text{ mA}}$$

$$I_1 = I_T - I_2 - I_3 = 500 \text{ mA} - 247 \text{ mA} = \mathbf{253 \text{ mA}}$$

$$R_1 = \frac{100 \text{ V}}{253 \text{ mA}} = \mathbf{395 \Omega}$$

27. $I_{\max} = 0.5 \text{ A}$

$$R_{T(\min)} = \frac{15 \text{ V}}{I_{\max}} = \frac{15 \text{ V}}{0.5 \text{ A}} = 30 \Omega$$

$$\frac{(68 \Omega)R_x}{68 \Omega + R_x} = R_{T(\min)}$$

$$(68 \Omega)R_x = (30 \Omega)(68 \Omega + R_x)$$

$$68R_x = 2040 + 30R_x$$

$$68R_x - 30R_x = 2040$$

$$38R_x = 2040$$

$$R_x = \mathbf{53.7 \Omega}$$

28. **Position A:**

$$I_1 = \frac{24 \text{ V}}{560 \text{ k}\Omega} = \mathbf{42.9 \mu\text{A}}$$

$$I_2 = \frac{24 \text{ V}}{220 \text{ k}\Omega} = \mathbf{109 \mu\text{A}}$$

$$I_3 = \frac{24 \text{ V}}{270 \text{ k}\Omega} = \mathbf{88.9 \mu\text{A}}$$

$$I_T = 42.9 \mu\text{A} + 109 \mu\text{A} + 88.9 \mu\text{A} = \mathbf{241 \mu\text{A}}$$

Position B:

$$I_1 = \mathbf{42.9 \mu\text{A}}$$

$$I_2 = \mathbf{109 \mu\text{A}}$$

$$I_3 = \mathbf{88.9 \mu\text{A}}$$

$$I_4 = \frac{24 \text{ V}}{1 \text{ M}\Omega} = \mathbf{24 \mu\text{A}}$$

$$I_5 = \frac{24 \text{ V}}{820 \text{ k}\Omega} = \mathbf{29.3 \mu\text{A}}$$

$$I_6 = \frac{24 \text{ V}}{2.2 \text{ M}\Omega} = \mathbf{10.9 \mu\text{A}}$$

$$I_T = 42.9 \mu\text{A} + 109 \mu\text{A} + 88.9 \mu\text{A} + 24 \mu\text{A} + 29.3 \mu\text{A} + 10.9 \mu\text{A} = \mathbf{305 \mu\text{A}}$$

Chapter 6

Position C:

$$I_4 = 24 \mu\text{A}$$

$$I_5 = 29.3 \mu\text{A}$$

$$I_6 = 10.9 \mu\text{A}$$

$$I_T = 24 \mu\text{A} + 29.3 \mu\text{A} + 10.9 \mu\text{A} = 64.2 \mu\text{A}$$

$$29. \quad I_3 = \frac{100 \text{ V}}{1.2 \text{ k}\Omega} = 83.3 \text{ mA}$$

$$I_2 = 250 \text{ mA} - 83.3 \text{ mA} = 166.7 \text{ mA}$$

$$I_T = 250 \text{ mA} + 50 \text{ mA} = 300 \text{ mA}$$

$$R_1 = \frac{100 \text{ V}}{50 \text{ mA}} = 2 \text{ k}\Omega$$

$$R_2 = \frac{100 \text{ V}}{166.7 \text{ mA}} = 600 \Omega$$

Section 6-6 Current Sources in Parallel

30. (a) $I_L = 1 \text{ mA} + 2 \text{ mA} = 3 \text{ mA}$
(b) $I_L = 50 \mu\text{A} - 40 \mu\text{A} = 10 \mu\text{A}$
(c) $I_L = 1 \text{ A} - 2.5 \text{ A} + 2 \text{ A} = 0.5 \text{ A}$

31. **Position A:** $I_R = 2.25 \text{ mA}$
Position B: $I_R = 4.75 \text{ mA}$
Position C: $I_R = 4.75 \text{ mA} + 2.25 \text{ mA} = 7 \text{ mA}$

Section 6-7 Current Dividers

$$32. \quad I_1 = \left(\frac{R_2}{R_1 + R_2} \right) I_T = \left(\frac{2.7 \text{ k}\Omega}{3.7 \text{ k}\Omega} \right) 3 \text{ A} = 2.19 \text{ A}$$

$$I_2 = \left(\frac{R_1}{R_1 + R_2} \right) I_T = \left(\frac{1 \text{ k}\Omega}{3.7 \text{ k}\Omega} \right) 3 \text{ A} = 0.811 \text{ A}$$

$$33. \quad (a) \quad I_1 = \left(\frac{R_2}{R_1 + R_2} \right) I_T = \left(\frac{2.2 \text{ M}\Omega}{3.2 \text{ M}\Omega} \right) 10 \mu\text{A} = 6.88 \mu\text{A}$$

$$I_2 = I_T - I_1 = 10 \mu\text{A} - 6.88 \mu\text{A} = 3.12 \mu\text{A}$$

$$(b) \quad I_x = \left(\frac{R_T}{R_x} \right) I_T$$

$$R_T = 525 \Omega$$

$$I_1 = \left(\frac{525 \Omega}{1000 \Omega} \right) 10 \text{ mA} = 5.25 \text{ mA}$$

$$I_2 = \left(\frac{525 \Omega}{2.2 \text{ k}\Omega} \right) 10 \text{ mA} = 2.39 \text{ mA}$$

$$I_3 = \left(\frac{525 \Omega}{3.3 \text{ k}\Omega} \right) 10 \text{ mA} = \mathbf{1.59 \text{ mA}}$$

$$I_4 = \left(\frac{525 \Omega}{6.8 \text{ k}\Omega} \right) 10 \text{ mA} = \mathbf{0.772 \text{ mA}}$$

$$34. \quad R_T = \frac{1}{\frac{1}{R} + \frac{1}{2R} + \frac{1}{3R} + \frac{1}{4R}} = R \left(1 + \frac{1}{2} + \frac{1}{3} + \frac{1}{4} \right) = 0.48R$$

$$I_R = \left(\frac{R_T}{R} \right) 10 \text{ mA} = \left(\frac{0.48R}{R} \right) 10 \text{ mA} = \mathbf{4.8 \text{ mA}}; \quad I_{2R} = \left(\frac{R_T}{2R} \right) 10 \text{ mA} = \left(\frac{0.48R}{2R} \right) 10 \text{ mA} = \mathbf{2.4 \text{ mA}};$$

$$I_{3R} = \left(\frac{R_T}{3R} \right) 10 \text{ mA} = \left(\frac{0.48R}{3R} \right) 10 \text{ mA} = \mathbf{1.59 \text{ mA}}; \quad I_{4R} = \left(\frac{R_T}{4R} \right) 10 \text{ mA} = \left(\frac{0.48R}{4R} \right) 10 \text{ mA} = \mathbf{1.2 \text{ mA}}$$

$$35. \quad R_T = 773 \Omega$$

$$I_3 = I_T - I_1 - I_2 - I_4 = 15.53 \text{ mA} - 3.64 \text{ mA} - 6.67 \text{ mA} - 3.08 \text{ mA} = 2.14 \text{ mA}$$

$$I_1 = \left(\frac{R_T}{R_1} \right) I_T$$

$$R_1 = \left(\frac{R_T}{I_1} \right) I_T = \left(\frac{773 \Omega}{3.64 \text{ mA}} \right) 15.53 \text{ mA} = \mathbf{3.3 \text{ k}\Omega}$$

$$R_2 = \left(\frac{R_T}{I_2} \right) I_T = \left(\frac{773 \Omega}{6.67 \text{ mA}} \right) 15.53 \text{ mA} = \mathbf{1.8 \text{ k}\Omega}$$

$$R_3 = \left(\frac{R_T}{I_3} \right) I_T = \left(\frac{773 \Omega}{2.14 \text{ mA}} \right) 15.53 \text{ mA} = \mathbf{5.6 \text{ k}\Omega}$$

$$R_4 = \left(\frac{R_T}{I_4} \right) I_T = \left(\frac{773 \Omega}{3.08 \text{ mA}} \right) 15.53 \text{ mA} = \mathbf{3.9 \text{ k}\Omega}$$

$$36. \quad (a) \quad I_T = 10 \text{ mA}, \quad I_M = 1 \text{ mA}$$

$$V_M = I_M R_M = (1 \text{ mA})(50 \Omega) = 50 \text{ mV}$$

$$I_{SH1} = 9 \text{ mA}$$

$$R_{SH1} = \frac{V_M}{I_{SH1}} = \frac{50 \text{ mV}}{9 \text{ mA}} = \mathbf{5.56 \Omega}$$

$$(b) \quad I_T = 100 \text{ mA}, \quad I_M = 1 \text{ mA}$$

$$V_M = I_M R_M = (1 \text{ mA})(50 \Omega) = 50 \text{ mV}$$

$$I_{SH2} = 99 \text{ mA}$$

$$R_{SH2} = \frac{V_M}{I_{SH2}} = \frac{50 \text{ mV}}{99 \text{ mA}} = \mathbf{0.505 \Omega}$$

Chapter 6

$$37. \quad (a) \quad R_{SH} = \frac{50 \text{ mV}}{50 \text{ A}} = \mathbf{1 \text{ m}\Omega}$$

$$(b) \quad I_{SH} = \frac{50 \text{ mV}}{1 \text{ m}\Omega} = 50 \text{ A}$$

$$I_{\text{meter}} = \frac{50 \text{ mV}}{10 \text{ k}\Omega} = \mathbf{5 \mu\text{A}}$$

Section 6-8 Power in Parallel Circuits

$$38. \quad P_T = 5(250 \text{ mW}) = \mathbf{1.25 \text{ W}}$$

$$39. \quad (a) \quad R_T = \frac{(1 \text{ M}\Omega)(2.2 \text{ M}\Omega)}{1 \text{ M}\Omega + 2.2 \text{ M}\Omega} = 687.5 \text{ k}\Omega$$
$$P_T = I^2 R_T = (10 \mu\text{A})^2 (687.5 \text{ k}\Omega) = \mathbf{68.8 \mu\text{W}}$$

$$(b) \quad R_T = \frac{1}{\frac{1}{R_1} + \frac{1}{R_2} + \frac{1}{R_3} + \frac{1}{R_4}} = \frac{1}{\frac{1}{1 \text{ k}\Omega} + \frac{1}{2.2 \text{ k}\Omega} + \frac{1}{3.3 \text{ k}\Omega} + \frac{1}{6.8 \text{ k}\Omega}} = 525 \Omega$$
$$P_T = I^2 R_T = (10 \text{ mA})^2 (525 \Omega) = \mathbf{52.5 \text{ mW}}$$

$$40. \quad P = VI$$

$$I_{\text{each}} = \frac{P}{V} = \frac{75 \text{ W}}{110 \text{ V}} = \mathbf{682 \text{ mA}}$$

$$I_T = 6(682 \text{ mA}) = \mathbf{4.09 \text{ A}}$$

$$41. \quad P_1 = P_T - P_2 = 2 \text{ W} - 0.75 \text{ W} = \mathbf{1.25 \text{ W}}$$

$$V_S = \frac{P_T}{I_T} = \frac{2 \text{ W}}{200 \text{ mA}} = \mathbf{10 \text{ V}}$$

$$I_2 = \frac{P_2}{V_S} = \frac{0.75 \text{ W}}{10 \text{ V}} = \mathbf{75 \text{ mA}}$$

$$R_2 = \frac{V_S}{I_2} = \frac{10 \text{ V}}{75 \text{ mA}} = \mathbf{133 \Omega}$$

$$I_1 = I_T - I_2 = 200 \text{ mA} - 75 \text{ mA} = \mathbf{125 \text{ mA}}$$

$$R_1 = \frac{V_S}{I_1} = \frac{10 \text{ V}}{125 \text{ mA}} = \mathbf{80 \Omega}$$

$$42. \quad (a) \quad P_T = I_T^2 R_T = (50 \text{ mA})^2 1 \text{ k}\Omega = 2.5 \text{ W}$$

$$\text{Number of resistors} = n = \frac{P_T}{P_{\text{each}}} = \frac{2.5 \text{ W}}{0.25 \text{ W}} = \mathbf{10}$$

$$(b) \quad R_T = \frac{R}{n}$$

$$R = nR_T = 10(1 \text{ k}\Omega) = \mathbf{10 \text{ k}\Omega}$$

$$(c) \quad I = \frac{I_T}{n} = \frac{50 \text{ mA}}{10} = \mathbf{5 \text{ mA}}$$

$$(d) \quad V_S = I_T R_T = (50 \text{ mA})(1 \text{ k}\Omega) = \mathbf{50 \text{ V}}$$

Section 6-10 Troubleshooting

$$43. \quad I_{\text{each}} = \frac{P}{V} = \frac{75 \text{ W}}{110 \text{ V}} = \mathbf{682 \text{ mA}}$$

$$I_T = 5(682 \text{ mA}) = \mathbf{3.41 \text{ A}}$$

$$44. \quad R_T = \frac{1}{\frac{1}{220 \text{ }\Omega} + \frac{1}{100 \text{ }\Omega} + \frac{1}{1 \text{ k}\Omega} + \frac{1}{560 \text{ }\Omega} + \frac{1}{270 \text{ }\Omega}} = 47.5 \text{ }\Omega$$

$$I_T = \frac{10 \text{ V}}{47.5 \text{ }\Omega} = 210.5 \text{ mA}$$

The measured current is 200.4 mA, which is 10.1 mA less than it should be. Therefore, one of the resistors is open.

$$R_? = \frac{V}{I} = \frac{10 \text{ V}}{10.1 \text{ mA}} = 990 \text{ }\Omega \cong 1 \text{ k}\Omega$$

The 1 k Ω resistor (R_3) is open.

$$45. \quad R_T = \frac{1}{\frac{1}{4.7 \text{ k}\Omega} + \frac{1}{10 \text{ k}\Omega} + \frac{1}{8.2 \text{ k}\Omega}} = 2.3 \text{ k}\Omega$$

$$I_T = \frac{25 \text{ V}}{2.3 \text{ k}\Omega} = 10.87 \text{ mA}$$

The meter indicates 7.82 mA. Therefore, a resistor must be open.

$$I_3 = \frac{25 \text{ V}}{8.2 \text{ k}\Omega} = 3.05 \text{ mA}$$

$$I = I_T - I_M = 10.87 \text{ mA} - 7.82 = 3.05 \text{ mA}$$

This shows that I_3 is missing from the total current as read on the meter. Therefore, R_3 (8.2 k Ω) is open.

$$46. \quad I_1 = \frac{25 \text{ V}}{4.7 \text{ k}\Omega} = 5.32 \text{ mA}$$

$$I_2 = \frac{25 \text{ V}}{10 \text{ k}\Omega} = 2.5 \text{ mA}$$

$$I_3 = \frac{25 \text{ V}}{8.2 \text{ k}\Omega} = 3.05 \text{ mA}$$

R_1 is open producing a total current of

$$I_T = I_2 + I_3 = 2.5 \text{ mA} + 3.05 \text{ mA} = 5.55 \text{ mA}$$

Chapter 6

47. Connect ohmmeter between the following pins:

Pins 1-2

Correct reading: $R = 1 \text{ k}\Omega \parallel 3.3 \text{ k}\Omega = 767 \Omega$

R_1 open: $R = 3.3 \text{ k}\Omega$

R_2 open: $R = 1 \text{ k}\Omega$

Pins 3-4

Correct reading: $R = 270 \Omega \parallel 390 \Omega = 159.5 \Omega$

R_3 open: $R = 390 \Omega$

R_4 open: $R = 270 \Omega$

Pins 5-6

Correct reading: $R = 1 \text{ M}\Omega \parallel 1.8 \text{ M}\Omega \parallel 680 \text{ k}\Omega \parallel 510 \text{ k}\Omega = 201 \text{ k}\Omega$

R_5 open: $R = 1.8 \text{ M}\Omega \parallel 680 \text{ k}\Omega \parallel 510 \text{ k}\Omega = 251 \text{ k}\Omega$

R_6 open: $R = 1 \text{ M}\Omega \parallel 680 \text{ k}\Omega \parallel 510 \text{ k}\Omega = 226 \text{ k}\Omega$

R_7 open: $R = 1 \text{ M}\Omega \parallel 1.8 \text{ M}\Omega \parallel 510 \text{ k}\Omega = 284 \text{ k}\Omega$

R_8 open: $R = 1 \text{ M}\Omega \parallel 1.8 \text{ M}\Omega \parallel 680 \text{ k}\Omega = 330 \text{ k}\Omega$

48. **Short between pins 2 and 4:**

(a) $R_{1-2} = R_1 \parallel R_2 \parallel R_3 \parallel R_4 \parallel R_{11} \parallel R_{12} + R_5 \parallel R_6 \parallel R_7 \parallel R_8 \parallel R_9 \parallel R_{10}$
 $= 10 \text{ k}\Omega \parallel 2.2 \text{ k}\Omega \parallel 2.2 \text{ k}\Omega \parallel 3.3 \text{ k}\Omega \parallel 18 \text{ k}\Omega \parallel 1 \text{ k}\Omega + 4.7 \text{ k}\Omega \parallel 4.7 \text{ k}\Omega \parallel 6.8 \text{ k}\Omega \parallel$
 $5.6 \text{ k}\Omega \parallel 1 \text{ k}\Omega \parallel 5.6 \text{ k}\Omega = 940 \Omega$

(b) $R_{2-3} = R_5 \parallel R_6 \parallel R_7 \parallel R_8 \parallel R_9 \parallel R_{10} = 4.7 \text{ k}\Omega \parallel 4.7 \text{ k}\Omega \parallel 6.8 \text{ k}\Omega \parallel 5.6 \text{ k}\Omega \parallel 1 \text{ k}\Omega \parallel 5.6 \text{ k}\Omega$
 $= 518 \Omega$

(c) $R_{3-4} = R_5 \parallel R_6 \parallel R_7 \parallel R_8 \parallel R_9 \parallel R_{10} = 4.7 \text{ k}\Omega \parallel 4.7 \text{ k}\Omega \parallel 6.8 \text{ k}\Omega \parallel 5.6 \text{ k}\Omega \parallel 1 \text{ k}\Omega \parallel 5.6 \text{ k}\Omega$
 $= 518 \Omega$

(d) $R_{1-4} = R_1 \parallel R_2 \parallel R_3 \parallel R_4 \parallel R_{11} \parallel R_{12} = 10 \text{ k}\Omega \parallel 2.2 \text{ k}\Omega \parallel 2.2 \text{ k}\Omega \parallel 3.3 \text{ k}\Omega \parallel 18 \text{ k}\Omega \parallel 1 \text{ k}\Omega$
 $= 422 \Omega$

49. **Short between pins 3 and 4:**

(a) $R_{1-2} = (R_1 \parallel R_2 \parallel R_3 \parallel R_4 \parallel R_{11} \parallel R_{12}) + (R_5 \parallel R_6 \parallel R_7 \parallel R_8 \parallel R_9 \parallel R_{10}) = 940 \Omega$

(b) $R_{2-3} = R_5 \parallel R_6 \parallel R_7 \parallel R_8 \parallel R_9 \parallel R_{10} = 518 \Omega$

(c) $R_{2-4} = R_5 \parallel R_6 \parallel R_7 \parallel R_8 \parallel R_9 \parallel R_{10} = 518 \Omega$

(d) $R_{1-4} = R_1 \parallel R_2 \parallel R_3 \parallel R_4 \parallel R_{11} \parallel R_{12} = 422 \Omega$

Multisim Troubleshooting and Analysis

50. $R_T = 547.97 \Omega$

51. R_2 is open.

52. $R_1 = 890 \Omega$

53. $V_S = 3.3 \text{ V}$

54. R_1 is open.

Chapter 7

Series-Parallel Circuits

Note: Solutions show conventional current direction.

Section 7-1 Identifying Series-Parallel Relationships

- See Figure 7-1.

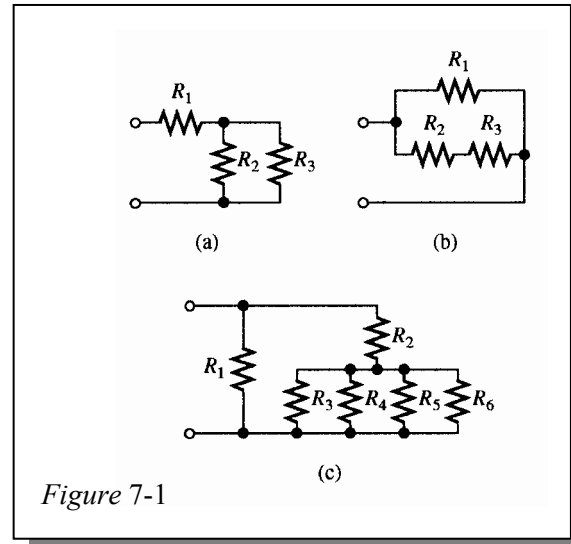

- See Figure 7-2.

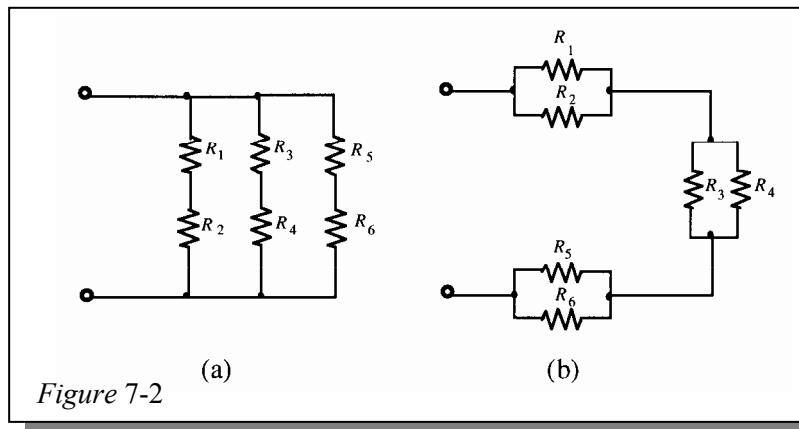

- R_1 and R_4 are in series with the parallel combination of R_2 and R_3 .
 - R_1 is in series with the parallel combination of R_2 , R_3 , and R_4 .
 - The parallel combination of R_2 and R_3 is in series with the parallel combination of R_4 and R_5 . This is all in parallel with R_1 .
- R_2 is in series with the parallel combination of R_3 and R_4 . This series-parallel combination is in parallel with R_1 .
 - All of the resistors are in parallel.
 - R_1 and R_2 are in series with the parallel combination of R_3 and R_4 . R_5 and R_8 are in series with the parallel combination of R_6 and R_7 . These two series-parallel combinations are in parallel with each other.

Chapter 7

5. See Figure 7-3.

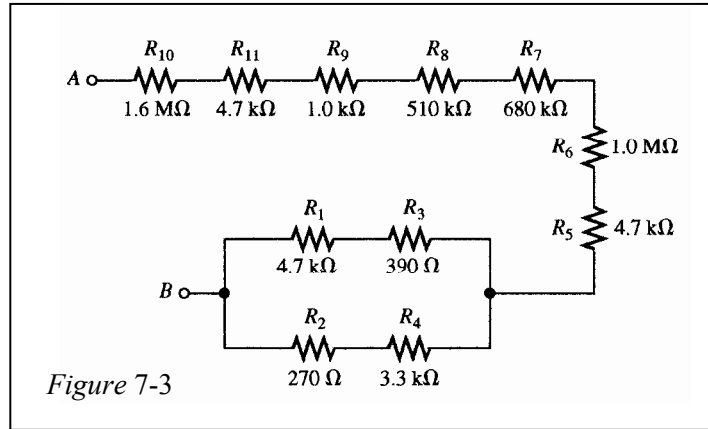

Figure 7-3

6. See Figure 7-4.

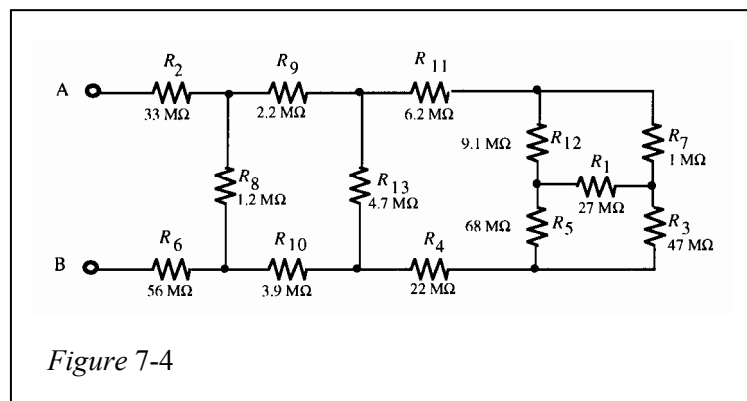

Figure 7-4

7. See Figure 7-5.

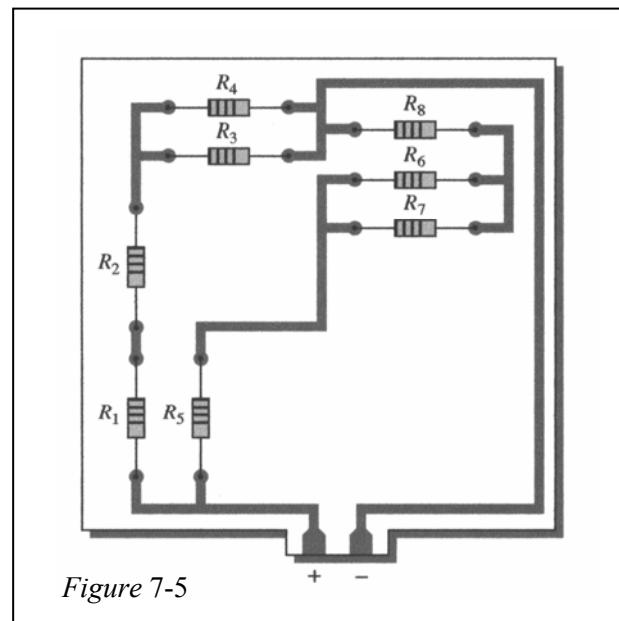

Figure 7-5

Section 7-2 Analysis of Series-Parallel Resistive Circuits

$$8. \quad R_T = \frac{R_1 R_2}{R_1 + R_2}$$

$$R_2 = \frac{R_1 R_T}{R_1 - R_T} = \frac{(1 \text{ k}\Omega)(667 \Omega)}{1 \text{ k}\Omega - 667 \Omega} = \mathbf{2.0 \text{ k}\Omega}$$

$$9. \quad (a) \quad R_T = R_1 + R_4 + \frac{R_2}{2} = 56 \Omega + 27 \Omega + \frac{100 \Omega}{2} = \mathbf{133 \Omega}$$

$$(b) \quad R_T = R_1 + \frac{1}{\frac{1}{R_2} + \frac{1}{R_3} + \frac{1}{R_4}} = 680 \Omega + \frac{1}{\frac{1}{680 \Omega} + \frac{1}{330 \Omega} + \frac{1}{180 \Omega}} = 680 \Omega + 99.4 \Omega = \mathbf{779 \Omega}$$

$$(c) \quad R_T = R_1 \parallel (R_2 \parallel R_3 + R_4 \parallel R_5) = R_1 \parallel (2.154 \text{ k}\Omega + 3.59 \text{ k}\Omega) = \mathbf{852 \Omega}$$

$$10. \quad (a) \quad R_T = R_1 \parallel (R_2 + R_3 \parallel R_4) = 1 \text{ k}\Omega \parallel (1 \text{ k}\Omega + 2.2 \text{ k}\Omega \parallel 3.3 \text{ k}\Omega) = \mathbf{699 \Omega}$$

$$(b) \quad R_T = \frac{1}{\frac{1}{1 \text{ M}\Omega} + \frac{1}{1 \text{ M}\Omega} + \frac{1}{3.3 \text{ M}\Omega} + \frac{1}{6.2 \text{ M}\Omega}} = \mathbf{406 \text{ k}\Omega}$$

$$(c) \quad R_A = R_1 + R_2 + \frac{R_3 R_4}{R_3 + R_4} = 1 \text{ k}\Omega + 1 \text{ k}\Omega + \frac{(10 \text{ k}\Omega)(4.7 \text{ k}\Omega)}{10 \text{ k}\Omega + 4.7 \text{ k}\Omega} = 5.2 \text{ k}\Omega$$

$$R_B = R_5 + R_8 + \frac{R_6 R_7}{R_6 + R_7} = 3.3 \text{ k}\Omega + 1.8 \text{ k}\Omega + \frac{6.8 \text{ k}\Omega}{2} = 8.5 \text{ k}\Omega$$

$$R_T = \frac{1}{\frac{1}{R_A} + \frac{1}{R_B}} = \frac{1}{\frac{1}{5.2 \text{ k}\Omega} + \frac{1}{8.5 \text{ k}\Omega}} = \mathbf{3.23 \text{ k}\Omega}$$

$$11. \quad (a) \quad I_T = \frac{1.5 \text{ V}}{133 \Omega} = 11.3 \text{ mA}$$

$$I_1 = I_4 = \mathbf{11.3 \text{ mA}}$$

$$I_2 = I_3 = \frac{11.3 \text{ mA}}{2} = \mathbf{5.64 \text{ mA}}$$

$$V_1 = (11.3 \text{ mA})(56 \Omega) = \mathbf{633 \text{ mV}}$$

$$V_4 = (11.3 \text{ mA})(27 \Omega) = \mathbf{305 \text{ mV}}$$

$$V_2 = V_3 = (5.64 \text{ mA})(100 \Omega) = \mathbf{564 \text{ mV}}$$

Chapter 7

(b) $I_T = \frac{3 \text{ V}}{779 \Omega} = 3.85 \text{ mA}$
 $V_1 = (3.85 \text{ mA})(680 \Omega) = \mathbf{2.62 \text{ V}}$
 $V_2 = V_3 = V_4 = V_S - I_T R_1 = 3 \text{ V} - (3.85 \text{ mA})(680 \Omega) = \mathbf{383 \text{ mV}}$
 $I_1 = I_T = \mathbf{3.85 \text{ mA}}$
 $I_2 = \frac{V_2}{R_2} = \frac{383 \text{ mV}}{680 \Omega} = \mathbf{563 \mu\text{A}}$
 $I_3 = \frac{V_3}{R_3} = \frac{383 \text{ mV}}{330 \Omega} = \mathbf{1.16 \text{ mA}}$
 $I_4 = \frac{V_4}{R_4} = \frac{383 \text{ mV}}{180 \Omega} = \mathbf{2.13 \text{ mA}}$

(c) $I_1 = \frac{5 \text{ V}}{1 \text{ k}\Omega} = \mathbf{5 \text{ mA}}$ $I_{\text{right}} = \frac{5 \text{ V}}{5.74 \text{ k}\Omega} = 871 \mu\text{A}$
 $I_2 = \left(\frac{3.3 \text{ k}\Omega}{9.5 \text{ k}\Omega} \right) 871 \mu\text{A} = \mathbf{303 \mu\text{A}}$
 $I_3 = \left(\frac{6.2 \text{ k}\Omega}{9.5 \text{ k}\Omega} \right) 871 \mu\text{A} = \mathbf{568 \mu\text{A}}$
 $I_4 = \left(\frac{5.6 \text{ k}\Omega}{15.6 \text{ k}\Omega} \right) 871 \mu\text{A} = \mathbf{313 \mu\text{A}}$
 $I_5 = \left(\frac{10 \text{ k}\Omega}{15.6 \text{ k}\Omega} \right) 871 \mu\text{A} = \mathbf{558 \mu\text{A}}$
 $V_1 = V_S = \mathbf{5 \text{ V}}$
 $V_2 = V_3 = (303 \mu\text{A})(6.2 \text{ k}\Omega) = \mathbf{1.88 \text{ V}}$
 $V_4 = V_5 = (313 \mu\text{A})(10 \text{ k}\Omega) = \mathbf{3.13 \text{ V}}$

12. (a) $I_T = \frac{1 \text{ V}}{699 \Omega} = 1.43 \text{ mA}$
 $I_1 = \left(\frac{2.32 \text{ k}\Omega}{3.32 \text{ k}\Omega} \right) 1.43 \text{ mA} = \mathbf{1 \text{ mA}}$
 $V_1 = (1 \text{ mA})(1 \text{ k}\Omega) = \mathbf{1 \text{ V}}$
 $I_2 = \left(\frac{1 \text{ k}\Omega}{3.32 \text{ k}\Omega} \right) 1.43 \text{ mA} = \mathbf{431 \mu\text{A}}$
 $V_2 = (431 \mu\text{A})(1 \text{ k}\Omega) = \mathbf{431 \text{ mV}}$
 $I_3 = \left(\frac{3.3 \text{ k}\Omega}{5.5 \text{ k}\Omega} \right) 431 \mu\text{A} = \mathbf{259 \mu\text{A}}$
 $V_3 = (259 \mu\text{A})(2.2 \text{ k}\Omega) = \mathbf{570 \text{ mV}}$
 $V_4 = V_3 = \mathbf{570 \text{ mV}}$
 $I_4 = \frac{570 \text{ mV}}{3.3 \text{ k}\Omega} = \mathbf{173 \mu\text{A}}$

$$(b) \quad V_1 = V_2 = V_3 = V_4 = 2 \text{ V}$$

$$I_1 = \frac{2 \text{ V}}{1 \text{ M}\Omega} = 2 \text{ }\mu\text{A}$$

$$I_2 = \frac{2 \text{ V}}{3.3 \text{ M}\Omega} = 606 \text{ nA}$$

$$I_3 = \frac{2 \text{ V}}{6.2 \text{ M}\Omega} = 323 \text{ nA}$$

$$I_4 = \frac{2 \text{ V}}{1 \text{ M}\Omega} = 2 \text{ }\mu\text{A}$$

$$(c) \quad I_T = \frac{5 \text{ V}}{3.23 \text{ k}\Omega} = 1.55 \text{ mA}$$

$$I_5 = \left(\frac{5.2 \text{ k}\Omega}{13.7 \text{ k}\Omega} \right) 1.55 \text{ mA} = 588 \text{ }\mu\text{A}$$

$$V_5 = (588 \text{ }\mu\text{A})(3.3 \text{ k}\Omega) = 1.94 \text{ V}$$

$$I_6 = I_7 = \frac{I_5}{2} = \frac{588 \text{ }\mu\text{A}}{2} = 294 \text{ }\mu\text{A}$$

$$V_6 = V_7 = (294 \text{ }\mu\text{A})(6.8 \text{ k}\Omega) = 2 \text{ V}$$

$$I_8 = I_5 = 588 \text{ }\mu\text{A}$$

$$V_8 = (588 \text{ }\mu\text{A})(1.8 \text{ k}\Omega) = 1.06 \text{ V}$$

$$I_1 = I_2 = \left(\frac{8.5 \text{ k}\Omega}{13.7 \text{ k}\Omega} \right) 1.55 \text{ mA} = 962 \text{ }\mu\text{A}$$

$$V_1 = V_2 = (962 \text{ }\mu\text{A})(1 \text{ k}\Omega) = 962 \text{ mV}$$

$$I_3 = \left(\frac{4.7 \text{ k}\Omega}{14.7 \text{ k}\Omega} \right) 962 \text{ }\mu\text{A} = 308 \text{ }\mu\text{A}$$

$$V_3 = V_4 = (308 \text{ }\mu\text{A})(10 \text{ k}\Omega) = 3.08 \text{ V}$$

$$I_4 = \left(\frac{10 \text{ k}\Omega}{14.7 \text{ k}\Omega} \right) 962 \text{ }\mu\text{A} = 654 \text{ }\mu\text{A}$$

13. SW1 closed, SW2 open:

$$R_T = R_2 = 220 \text{ }\Omega$$

SW1 closed, SW2 closed:

$$R_T = R_2 \parallel R_3 = 220 \text{ }\Omega \parallel 2.2 \text{ k}\Omega = 200 \text{ }\Omega$$

SW1 open, SW2 open:

$$R_T = R_1 + R_2 = 100 \text{ }\Omega + 220 \text{ }\Omega = 320 \text{ }\Omega$$

SW1 open, SW2 closed:

$$R_T = R_1 + R_2 \parallel R_3 = 100 \text{ }\Omega + 200 \text{ }\Omega = 300 \text{ }\Omega$$

14. $R_{AB} = (10 \text{ k}\Omega + 5.6 \text{ k}\Omega) \parallel 4.7 \text{ k}\Omega = 15.6 \text{ k}\Omega \parallel 4.7 \text{ k}\Omega = 3.61 \text{ k}\Omega$

The 1.8 k Ω and the two 1 k Ω s are shorted).

Chapter 7

15. $V_{AG} = 100 \text{ V}$

$$R_{AC} = (4.7 \text{ k}\Omega + 5.6 \text{ k}\Omega) \parallel 10 \text{ k}\Omega = 5.07 \text{ k}\Omega$$

$$R_{CG} = 2 \text{ k}\Omega \parallel 1.8 \text{ k}\Omega = 947 \text{ }\Omega$$

$$V_{AC} = \left(\frac{5.07 \text{ k}\Omega}{6.02 \text{ k}\Omega} \right) 100 \text{ V} = 84.2 \text{ V}$$

$$V_{CG} = \left(\frac{947 \text{ }\Omega}{6.02 \text{ k}\Omega} \right) 100 \text{ V} = 15.7 \text{ V}$$

$$V_{DG} = \left(\frac{1 \text{ k}\Omega}{2 \text{ k}\Omega} \right) V_{CG} = \left(\frac{1 \text{ k}\Omega}{2 \text{ k}\Omega} \right) 15.7 \text{ V} = 7.87 \text{ V}$$

$$V_{BC} = \left(\frac{5.6 \text{ k}\Omega}{10.3 \text{ k}\Omega} \right) V_{AC} = \left(\frac{5.6 \text{ k}\Omega}{10.3 \text{ k}\Omega} \right) 84.2 \text{ V} = 45.8 \text{ V}$$

$$V_{BG} = V_{CG} + V_{BC} = 15.7 \text{ V} + 45.8 \text{ V} = 61.5 \text{ V}$$

16. $V_A = \left(\frac{56 \text{ k}\Omega}{716 \text{ k}\Omega} \right) 50 \text{ V} = 3.91 \text{ V}$ $V_B = \left(\frac{616 \text{ k}\Omega}{716 \text{ k}\Omega} \right) 50 \text{ V} = 43.0 \text{ V}$

$$V_C = 50 \text{ V} \quad V_D = \left(\frac{100 \text{ k}\Omega}{1.1 \text{ M}\Omega} \right) 50 \text{ V} = 4.55 \text{ V}$$

17. Measure the voltage at point A with respect to ground and the voltage at point B with respect to ground. The difference is V_{R2} .

$$V_{R2} = V_B - V_A$$

18. $R_T = (10 \text{ k}\Omega \parallel (4.7 \text{ k}\Omega + 5.6 \text{ k}\Omega)) + (1.8 \text{ k}\Omega \parallel (1 \text{ k}\Omega + 1 \text{ k}\Omega))$
 $= 10 \text{ k}\Omega \parallel 10.3 \text{ k}\Omega + 1.8 \text{ k}\Omega \parallel 2 \text{ k}\Omega$
 $= 5.07 \text{ k}\Omega + 947 \text{ }\Omega = 6.02 \text{ k}\Omega$

19. $R_T = (R_1 + R_2 + R_3) \parallel R_4 \parallel (R_5 + R_6)$
 $= (100 \text{ k}\Omega + 560 \text{ k}\Omega + 56 \text{ k}\Omega) \parallel 1.0 \text{ M}\Omega \parallel (1.0 \text{ M}\Omega + 100 \text{ k}\Omega)$
 $= 716 \text{ k}\Omega \parallel 1.0 \text{ M}\Omega \parallel 1.1 \text{ M}\Omega = 303 \text{ k}\Omega$

20. **Resistance of the right branch:**

$$R_R = R_2 + R_5 \parallel R_6 + R_7 + R_8 = 330 \text{ }\Omega + 600 \text{ }\Omega + 680 \text{ }\Omega + 100 \text{ }\Omega = 1710 \text{ }\Omega$$

Resistance of the left branch:

$$R_L = R_3 + R_4 = 470 \text{ }\Omega + 560 \text{ }\Omega = 1030 \text{ }\Omega$$

Total resistance:

$$R_T = R_1 + R_L \parallel R_R = 1 \text{ k}\Omega + 643 \text{ }\Omega = 1.64 \text{ k}\Omega$$

$$I_T = \frac{100 \text{ V}}{1.64 \text{ k}\Omega} = 60.9 \text{ mA}$$

Current in the right branch:

$$I_R = \left(\frac{R_L}{R_L + R_R} \right) I_T = \left(\frac{1030 \text{ }\Omega}{2740 \text{ }\Omega} \right) 60.9 \text{ mA} = 22.9 \text{ mA}$$

Current in the left branch:

$$I_L = \left(\frac{R_R}{R_L + R_R} \right) I_T = \left(\frac{1710 \text{ }\Omega}{2740 \text{ }\Omega} \right) 60.9 \text{ mA} = 38.0 \text{ mA}$$

With respect to the negative source terminal:

$$V_A = I_L R_4 = (38.0 \text{ mA})(560 \Omega) = 21.3 \text{ V}$$

$$V_B = I_R(R_7 + R_8) = (22.9 \text{ mA})(780 \Omega) = 17.9 \text{ V}$$

$$V_{AB} = V_A - V_B = 21.3 \text{ V} - 17.9 \text{ V} = \mathbf{3.4 \text{ V}}$$

$$21. \quad (a) \quad I_2 = \left(\frac{R_1}{R_1 + R_2} \right) I_T$$

$$1 \text{ mA} = \left(\frac{47 \text{ k}\Omega}{47 \text{ k}\Omega + R_2} \right) I_T$$

$$47 \text{ k}\Omega + R_2 = (47 \text{ k}\Omega) I_T$$

Also,

$$I_T = \frac{V}{R_T} = \frac{220}{33 \text{ k}\Omega + \frac{(47 \text{ k}\Omega)R_2}{(47 \text{ k}\Omega) + R_2}}$$

Substituting the expression for I_T into $47 \text{ k}\Omega + R_2 = (47 \text{ k}\Omega)I_T$.

$$47 \text{ k}\Omega + R_2 = 47 \text{ k}\Omega \left(\frac{220}{33 \text{ k}\Omega + \frac{(47 \text{ k}\Omega)R_2}{47 \text{ k}\Omega + R_2}} \right)$$

$$(47 \text{ k}\Omega + R_2) \left(33 \text{ k}\Omega + \frac{(47 \text{ k}\Omega)R_2}{47 \text{ k}\Omega + R_2} \right) = 47 \text{ k}\Omega(220)$$

$$(80 \text{ k}\Omega)R_2 = 47 \text{ k}\Omega(220) - (47 \text{ k}\Omega)(33 \text{ k}\Omega)$$

$$R_2 = \frac{47 \text{ k}\Omega(220 - 33 \text{ k}\Omega)}{80 \text{ k}\Omega} = 109.9 \text{ k}\Omega \cong \mathbf{110 \text{ k}\Omega}$$

$$(b) \quad P_2 = I_2^2 R_2 = (1 \text{ mA})^2 110 \text{ k}\Omega = 0.11 \text{ W} = \mathbf{110 \text{ mW}}$$

$$22. \quad R_{AB} = R_1 \parallel (R_2 + R_7 + R_8) = 1 \text{ k}\Omega \parallel (2.2 \text{ k}\Omega + 3.3 \text{ k}\Omega + 4.7 \text{ k}\Omega) = 1 \text{ k}\Omega \parallel 10.2 \text{ k}\Omega = \mathbf{911 \Omega}$$

$$R_{AG} = R_8 \parallel (R_1 + R_2 + R_7) = 4.7 \text{ k}\Omega \parallel (1 \text{ k}\Omega + 2.2 \text{ k}\Omega + 3.3 \text{ k}\Omega) = 4.7 \text{ k}\Omega \parallel 6.5 \text{ k}\Omega = \mathbf{2.73 \text{ k}\Omega}$$

$$R_{AC} = (R_1 + R_2) \parallel (R_7 + R_8) = (1 \text{ k}\Omega + 2.2 \text{ k}\Omega) \parallel (3.3 \text{ k}\Omega + 4.7 \text{ k}\Omega) = 3.2 \text{ k}\Omega \parallel 8 \text{ k}\Omega = \mathbf{2.29 \text{ k}\Omega}$$

$$R_{AD} = R_{AC} + R_3 \parallel (R_4 + R_5 + R_6) = 2.29 \text{ k}\Omega + 1 \text{ k}\Omega \parallel 10.2 \text{ k}\Omega = \mathbf{3.20 \text{ k}\Omega}$$

$$R_{AE} = R_{AC} + (R_3 + R_4) \parallel (R_5 + R_6) = 2.29 \text{ k}\Omega + 3.2 \text{ k}\Omega \parallel 8 \text{ k}\Omega = \mathbf{4.58 \text{ k}\Omega}$$

$$R_{AF} = R_{AC} + R_6 \parallel (R_3 + R_4 + R_5) = 2.29 \text{ k}\Omega + 4.7 \text{ k}\Omega \parallel 6.5 \text{ k}\Omega = \mathbf{5.02 \text{ k}\Omega}$$

$$23. \quad R_{AB} = (R_1 + R_2) \parallel R_4 \parallel R_3 = 6.6 \text{ k}\Omega \parallel 3.3 \text{ k}\Omega \parallel 3.3 \text{ k}\Omega = \mathbf{1.32 \text{ k}\Omega}$$

Note: R_5 and R_6 is shorted out (ACD) and is not a factor in the total resistance.

$$R_{BC} = R_4 \parallel (R_1 + R_2) \parallel R_3 = \mathbf{1.32 \text{ k}\Omega}$$

$$R_{CD} = \mathbf{0 \Omega}$$

Chapter 7

24. $V_2 = V_5 - V_6 = 5 \text{ V} - 1 \text{ V} = 4 \text{ V}$
 $I_2 = I_6 = \frac{2 \text{ W}}{4 \text{ V}} = 0.5 \text{ A}$
 $I_5 = I_8 - I_6 = 1 \text{ A} - 0.5 \text{ A} = 0.5 \text{ A}$
 $I_1 = I_2 + I_5 + I_4 = 0.5 \text{ A} + 0.5 \text{ A} + 1 \text{ A} = 2 \text{ A}$
 $I_3 = I_T - I_1 = 4 \text{ A} - 2 \text{ A} = 2 \text{ A}$
 $V_7 = V_S - V_3 = 40 \text{ V} - 20 \text{ V} = 20 \text{ V}$
 $V_1 = \frac{20 \text{ W}}{2 \text{ A}} = 10 \text{ V}$
 $V_4 = V_3 - V_1 = 10 \text{ V}$
 $V_8 = V_4 - V_5 = 5 \text{ V}$

$R_1 = \frac{10 \text{ V}}{2 \text{ A}} = 5 \Omega$ $R_7 = \frac{20 \text{ V}}{4 \text{ A}} = 5 \Omega$
 $R_2 = \frac{4 \text{ V}}{0.5 \text{ A}} = 8 \Omega$ $R_8 = \frac{5 \text{ V}}{1 \text{ A}} = 5 \Omega$
 $R_3 = \frac{20 \text{ V}}{2 \text{ A}} = 10 \Omega$
 $R_4 = \frac{10 \text{ V}}{1 \text{ A}} = 10 \Omega$
 $R_5 = \frac{5 \text{ V}}{0.5 \text{ A}} = 10 \Omega$
 $R_6 = \frac{1 \text{ V}}{0.5 \text{ A}} = 2 \Omega$

Section 7-3 Voltage Dividers with Resistive Loads

25. $V_{\text{OUT(unloaded)}} = \left(\frac{56 \text{ k}\Omega}{112 \text{ k}\Omega} \right) 15 \text{ V} = 7.5 \text{ V}$
 56 k Ω in parallel with a 1 M Ω load is
 $R_{\text{eq}} = \frac{(56 \text{ k}\Omega)(1 \text{ M}\Omega)}{56 \text{ k}\Omega + 1 \text{ M}\Omega} = 53 \text{ k}\Omega$
 $V_{\text{OUT(loaded)}} = \left(\frac{56 \text{ k}\Omega}{109 \text{ k}\Omega} \right) 15 \text{ V} = 7.29 \text{ V}$

26. See Figure 7-6.

$$V_A = \left(\frac{6.6 \text{ k}\Omega}{9.9 \text{ k}\Omega} \right) 12 \text{ V} = 8 \text{ V}$$

$$V_B = \left(\frac{3.3 \text{ k}\Omega}{9.9 \text{ k}\Omega} \right) 12 \text{ V} = 4 \text{ V}$$

With a 10 k Ω resistor connected from tap A to ground:

$$R_{AB} = \frac{(6.6 \text{ k}\Omega)(10 \text{ k}\Omega)}{6.6 \text{ k}\Omega + 10 \text{ k}\Omega} = 3.98 \text{ k}\Omega$$

$$V_{A(\text{loaded})} = \left(\frac{3.98 \text{ k}\Omega}{7.28 \Omega} \right) 12 \text{ V} = 6.56 \text{ V}$$

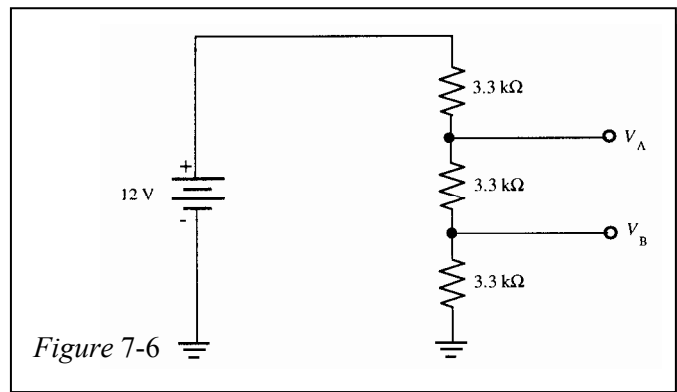

27. The 47 k Ω will result in a smaller decrease in output voltage because it has less effect on the circuit resistance than does the smaller resistance.

28. $R_T = 10 \text{ k}\Omega + 5.6 \text{ k}\Omega + 2.7 \text{ k}\Omega = 18.3 \text{ k}\Omega$
 $V_{\text{OUT(NL)}} = \left(\frac{R_2 + R_3}{R_1 + R_2 + R_3} \right) V_S = \left(\frac{8.3 \text{ k}\Omega}{18.3 \text{ k}\Omega} \right) 22 \text{ V} = \mathbf{9.98 \text{ V}}$
 With a $100 \text{ k}\Omega$ load:
 $R_T = R_1 + \frac{(R_2 + R_3)R_L}{R_2 + R_3 + R_L} = 10 \text{ k}\Omega + \frac{(8.3 \text{ k}\Omega)(100 \text{ k}\Omega)}{108.3 \text{ k}\Omega} = 17.7 \text{ k}\Omega$
 $V_{\text{OUT}} = \left(\frac{7.7 \text{ k}\Omega}{17.7 \text{ k}\Omega} \right) 22 \text{ V} = \mathbf{9.57 \text{ V}}$
29. $R_{AB} = \frac{(8.3 \text{ k}\Omega)(33 \text{ k}\Omega)}{8.3 \text{ k}\Omega + 33 \text{ k}\Omega} = 6.63 \text{ k}\Omega$
 $V_{AB} = \left(\frac{6.63 \text{ k}\Omega}{10 \text{ k}\Omega + 6.63 \text{ k}\Omega} \right) 22 \text{ V} = \mathbf{8.77 \text{ V}}$
30. $R_T = 10 \text{ k}\Omega + 5.6 \text{ k}\Omega + 2.7 \text{ k}\Omega = 18.3 \text{ k}\Omega$
 $I = \frac{22 \text{ V}}{18.3 \text{ k}\Omega} = \mathbf{1.2 \text{ mA}}$
 $R_T = 10 \text{ k}\Omega + \frac{(8.3 \text{ k}\Omega)(33 \text{ k}\Omega)}{8.3 \text{ k}\Omega + 33 \text{ k}\Omega} = 16.6 \text{ k}\Omega$
 $I = \frac{22 \text{ V}}{16.6 \text{ k}\Omega} = \mathbf{1.33 \text{ mA}}$

31. See Figure 7-7. $R_1 + 2R_2 = 2 \text{ k}\Omega$
 $R_T = \frac{10 \text{ V}}{5 \text{ mA}} = 2 \text{ k}\Omega$ $2R_2 + 2R_2 = 2 \text{ k}\Omega$
 $R_1 = R_2 + R_3$ $4R_2 = 2 \text{ k}\Omega$
 $R_2 = R_3$ $R_2 = R_3 = \mathbf{500 \Omega}$
 $R_1 = 2R_2$ $R_1 = R_2 + R_3 = \mathbf{1000 \Omega}$

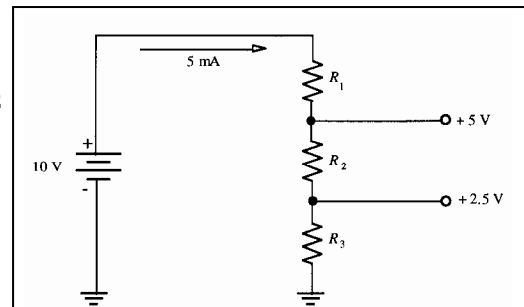

Figure 7-7

With a $1 \text{ k}\Omega$ load on the lower tap:

$$1 \text{ k}\Omega \parallel 500 \Omega = 333 \Omega$$

$$I_T = \frac{10 \text{ V}}{1 \text{ k}\Omega + 500 \Omega + 333 \Omega} = 5.46 \text{ mA}$$

$$V_{\text{lower tap}} = (333 \Omega)(5.46 \text{ mA}) = \mathbf{1.82 \text{ V}}$$

$$V_{\text{upper tap}} = (500 \Omega + 333 \Omega)(5.46 \text{ mA}) = \mathbf{4.55 \text{ V}}$$

With a $1 \text{ k}\Omega$ load on the upper tap:

$$I_T = \frac{10 \text{ V}}{1 \text{ k}\Omega + 1 \text{ k}\Omega / 2} = 6.67 \text{ mA}$$

$$V_{\text{upper tap}} = (500 \Omega)(6.67 \text{ mA}) = \mathbf{3.33 \text{ V}}$$

$$V_{\text{lower tap}} = \frac{3.33 \text{ V}}{2} = \mathbf{1.67 \text{ V}}$$

Chapter 7

32. Position 1:

$$R_T = 10 \text{ k}\Omega + 30 \text{ k}\Omega \parallel 68 \text{ k}\Omega = 10 \text{ k}\Omega + 20.82 \text{ k}\Omega = 30.8 \text{ k}\Omega$$

$$V_1 = \left(\frac{20.8 \text{ k}\Omega}{30.8 \text{ k}\Omega} \right) 120 \text{ V} = \mathbf{81.0 \text{ V}}$$

$$V_2 = \left(\frac{20 \text{ k}\Omega}{30 \text{ k}\Omega} \right) 81 \text{ V} = \mathbf{54.0 \text{ V}}$$

$$V_3 = \left(\frac{10 \text{ k}\Omega}{30 \text{ k}\Omega} \right) 81 \text{ V} = \mathbf{27.0 \text{ V}}$$

Position 2:

$$R_T = 20 \text{ k}\Omega + 20 \text{ k}\Omega \parallel 68 \text{ k}\Omega = 20 \text{ k}\Omega + 15.5 \text{ k}\Omega = 35.5 \text{ k}\Omega$$

$$V_1 = \left(\frac{10 \text{ k}\Omega + 15.5 \text{ k}\Omega}{35.5 \text{ k}\Omega} \right) 120 \text{ V} = \mathbf{86.2 \text{ V}}$$

$$V_2 = \left(\frac{15.5 \text{ k}\Omega}{35.5 \text{ k}\Omega} \right) 81 \text{ V} = \mathbf{52.4 \text{ V}}$$

$$V_3 = \left(\frac{10 \text{ k}\Omega}{20 \text{ k}\Omega} \right) 52.4 \text{ V} = \mathbf{26.2 \text{ V}}$$

Position 3:

$$R_T = 30 \text{ k}\Omega + 10 \text{ k}\Omega \parallel 68 \text{ k}\Omega = 30 \text{ k}\Omega + 8.72 \text{ k}\Omega = 38.7 \text{ k}\Omega$$

$$V_1 = \left(\frac{20 \text{ k}\Omega + 8.72 \text{ k}\Omega}{38.7 \text{ k}\Omega} \right) 120 \text{ V} = \mathbf{89.0 \text{ V}}$$

$$V_2 = \left(\frac{10 \text{ k}\Omega + 8.72 \text{ k}\Omega}{38.7 \text{ k}\Omega} \right) 81 \text{ V} = \mathbf{58.0 \text{ V}}$$

$$V_3 = \left(\frac{8.72 \text{ k}\Omega}{38.7 \text{ k}\Omega} \right) 81 \text{ V} = \mathbf{27.0 \text{ V}}$$

33. (a) $V_G = \left(\frac{R_2}{R_1 + R_2} \right) V_{DD} = \left(\frac{270 \text{ k}\Omega}{2.47 \text{ M}\Omega} \right) 16 \text{ V} = \mathbf{1.75 \text{ V}}$

$$V_S = V_G + 1.5 \text{ V} = 1.75 \text{ V} + 1.5 \text{ V} = \mathbf{3.25 \text{ V}}$$

(b) $I_1 = \frac{V_{DD} - V_G}{R_1} = \frac{16 \text{ V} - 1.75 \text{ V}}{2.2 \text{ M}\Omega} = \mathbf{6.48 \mu\text{A}}$

$$I_2 = I_1 = \frac{V_G}{R_2} = \frac{1.75 \text{ V}}{270 \text{ k}\Omega} = \mathbf{6.48 \mu\text{A}}$$

$$I_S = \frac{V_S}{R_S} = \frac{3.25 \text{ V}}{1.5 \text{ k}\Omega} = \mathbf{2.17 \text{ mA}}$$

$$I_D = I_S = \mathbf{2.17 \text{ mA}}$$

(c) $V_D = V_{DD} - I_D R_D = 16 \text{ V} - (2.17 \text{ mA})(4.7 \text{ k}\Omega) = 16 \text{ V} - 10.2 \text{ V} = \mathbf{5.8 \text{ V}}$

$$V_{DS} = V_D - V_S = 5.8 \text{ V} - 3.25 \text{ V} = \mathbf{2.55 \text{ V}}$$

$$V_{DG} = V_D - V_G = 5.8 \text{ V} - 1.75 \text{ V} = \mathbf{4.05 \text{ V}}$$

34. $I_{\max} = 100 \text{ mA}$
 $R_T = \frac{24 \text{ V}}{100 \text{ mA}} = 240 \Omega$
 $\left(\frac{R_2}{R_T}\right) 24 \text{ V} = 6 \text{ V}$
 $24R_2 = 6R_T$
 $R_2 = \frac{6(240 \Omega)}{24} = 60 \Omega$
 $R_I = 240 \Omega - 60 \Omega = 180 \Omega$
 With load:
 $R_2 \parallel R_L = 60 \Omega \parallel 1000 \Omega = 56.6 \Omega$
 $V_{\text{OUT}} = \left(\frac{56.6 \Omega}{180 \Omega + 56.6 \Omega}\right) 24 \text{ V} = 5.74 \text{ V}$

Section 7-4 Loading Effect of a Voltmeter

35. The voltmeter presents the least load when set on the **1000 V** range.
 For example, assuming $20,000 \Omega/\text{V}$:

$$R_{\text{internal}} = (20,000 \Omega/\text{V})(1 \text{ V}) = 20 \text{ k}\Omega \text{ on the } 1 \text{ V range}$$

$$R_{\text{internal}} = (20,000 \Omega/\text{V})(1000 \text{ V}) = 20 \text{ M}\Omega \text{ on the } 1000 \text{ V range}$$

36. (a) $R_{\text{internal}} = (20,000 \Omega/\text{V})(0.5 \text{ V}) = 10 \text{ k}\Omega$
 (b) $R_{\text{internal}} = (20,000 \Omega/\text{V})(1 \text{ V}) = 20 \text{ k}\Omega$
 (c) $R_{\text{internal}} = (20,000 \Omega/\text{V})(5 \text{ V}) = 100 \text{ k}\Omega$
 (d) $R_{\text{internal}} = (20,000 \Omega/\text{V})(50 \text{ V}) = 1 \text{ M}\Omega$
 (e) $R_{\text{internal}} = (20,000 \Omega/\text{V})(100 \text{ V}) = 2 \text{ M}\Omega$
 (f) $R_{\text{internal}} = (20,000 \Omega/\text{V})(1000 \text{ V}) = 20 \text{ M}\Omega$

37. $V_{R_4} = \left(\frac{R_4}{R_1 + R_2 \parallel R_3 + R_4}\right) 1.5 \text{ V} = \left(\frac{27 \Omega}{133 \Omega}\right) 1.5 \text{ V} = 0.305 \text{ V}$ actual

- (a) Use the **0.5 V range** to measure 0.305 V.

(b) $R_{\text{internal}} = (20,000 \Omega/\text{V})(0.5 \text{ V}) = 10 \text{ k}\Omega$

$$27 \Omega \parallel 10 \text{ k}\Omega = 26.93 \Omega$$

$$V_{R_4} = \left(\frac{26.93 \Omega}{132.93 \Omega}\right) 1.5 \text{ V} = 0.304 \text{ V with meter connected}$$

$$0.305 \text{ V} - 0.304 \text{ V} = \mathbf{0.001 \text{ V}} \text{ less with meter}$$

Chapter 7

$$38. \quad V_{R_4} = \left(\frac{R_2 \parallel R_3 \parallel R_4}{R_2 \parallel R_3 \parallel R_4 + R_1} \right) 3 \text{ V} = \left(\frac{99.4 \Omega}{779.4 \Omega} \right) 3 \text{ V} = 0.383 \text{ V actual}$$

(a) Use the 0.5 V range to measure 0.383 V.

$$(b) \quad R_{\text{internal}} = (20,000 \Omega/\text{V})(0.5 \text{ V}) = 10 \text{ k}\Omega$$

$$99.4 \Omega \parallel 10 \text{ k}\Omega = 98.4 \Omega$$

$$V_{R_4} = \left(\frac{98.4 \Omega}{778.4 \Omega} \right) 3 \text{ V} = 0.379 \text{ V with meter connected}$$

$$0.383 \text{ V} - 0.379 \text{ V} = 0.004 \text{ V less with meter}$$

Section 7-5 Ladder Networks

39. The circuit in Figure 7-77 in the text is redrawn here in Figure 7-8 to make the analysis simpler.

$$(a) \quad R_T = 560 \Omega \parallel 524.5 \Omega = \mathbf{271 \Omega}$$

$$(b) \quad I_T = \frac{60 \text{ V}}{271 \Omega} = \mathbf{221 \text{ mA}}$$

$$(c) \quad I_2 = \left(\frac{271 \Omega}{524.5 \Omega} \right) 221 \text{ mA} = 114 \text{ mA}$$

$$I_{910} = \left(\frac{468.5 \Omega}{910 \Omega} \right) 114 \text{ mA} = \mathbf{58.7 \text{ mA}}$$

- (d) The voltage across the 437.5Ω parallel combination of the 560Ω and the two series $1 \text{ k}\Omega$ resistors is determined as follows:

$$I_4 = \left(\frac{468.5 \Omega}{965.5 \Omega} \right) 114 \text{ mA} = 55 \text{ mA}$$

$$V_{437.5 \Omega} = I_4(437.5 \Omega) = (55 \text{ mA})(437.5 \Omega) = 24.06 \text{ V}$$

$$V_{AB} = \left(\frac{1 \text{ k}\Omega}{2 \text{ k}\Omega} \right) 24.06 \text{ V} = 12 \text{ V}$$

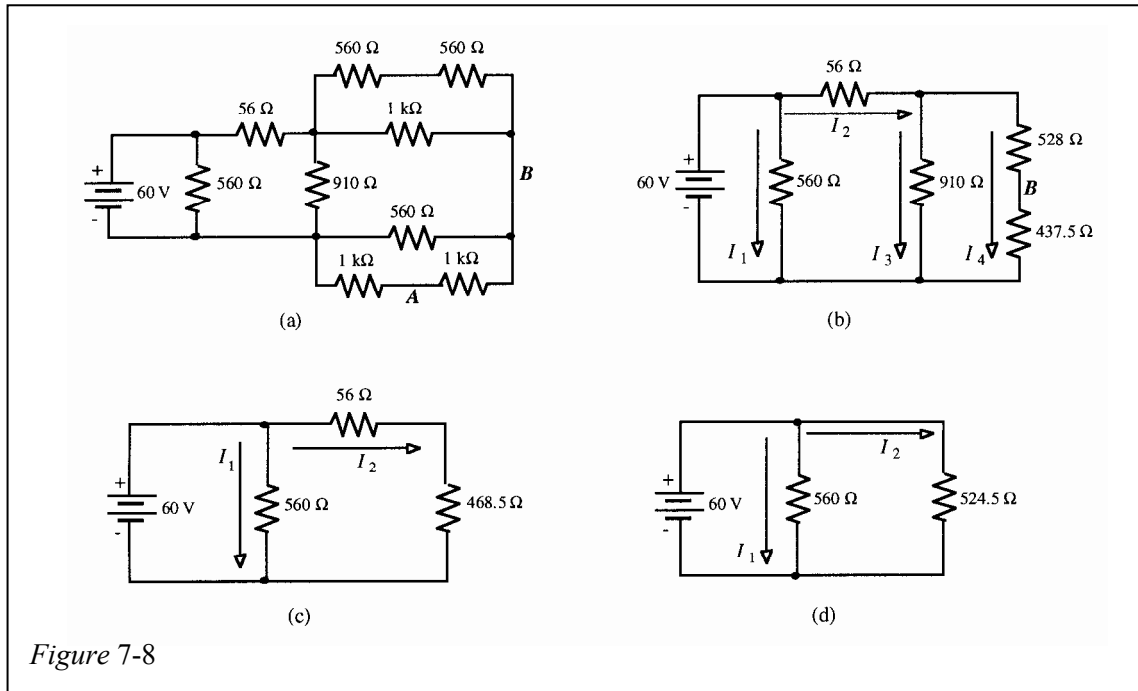

Figure 7-8

40. The total resistance is determined in the steps shown in Figure 7-9.

$$R_T = 6.66 \text{ k}\Omega$$

$$V_A = \left(\frac{1.06 \text{ k}\Omega}{6.66 \text{ k}\Omega} \right) 18 \text{ V} = 2.86 \text{ V}$$

$$V_B = \left(\frac{1.05 \text{ k}\Omega}{2.05 \text{ k}\Omega} \right) 2.86 \text{ V} = 1.47 \text{ V}$$

$$V_C = \left(\frac{1 \text{ k}\Omega}{2 \text{ k}\Omega} \right) 1.47 \text{ V} = 735 \text{ mV}$$

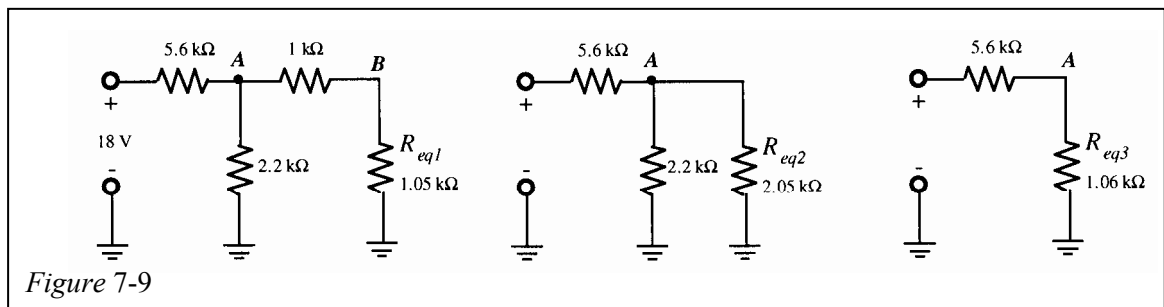

Figure 7-9

Chapter 7

41. The circuit is simplified in Figure 7-10 to determine R_T .

$$R_T = 621 \Omega$$

From Figure 7-10(e):

$$I_T = I_9 = I_T = 16.1 \text{ mA}$$

From Figure 7-10(c):

$$I_2 = \left(\frac{420.8 \Omega}{820 \Omega} \right) 16.1 \text{ mA} = 8.27 \text{ mA}$$

From Figure 7-10(b):

$$I_3 = I_8 = \left(\frac{420.8 \Omega}{864.5 \Omega} \right) 16.1 \text{ mA} = 7.84 \text{ mA}$$

From Figure 7-10(a):

$$I_4 = \left(\frac{424.5 \Omega}{820 \Omega} \right) 7.84 \text{ mA} = 4.06 \text{ mA}$$

From the original circuit:

$$I_5 = I_6 = I_7 = I_3 - I_4 = 7.84 \text{ mA} - 4.06 \text{ mA} = 3.78 \text{ mA}$$

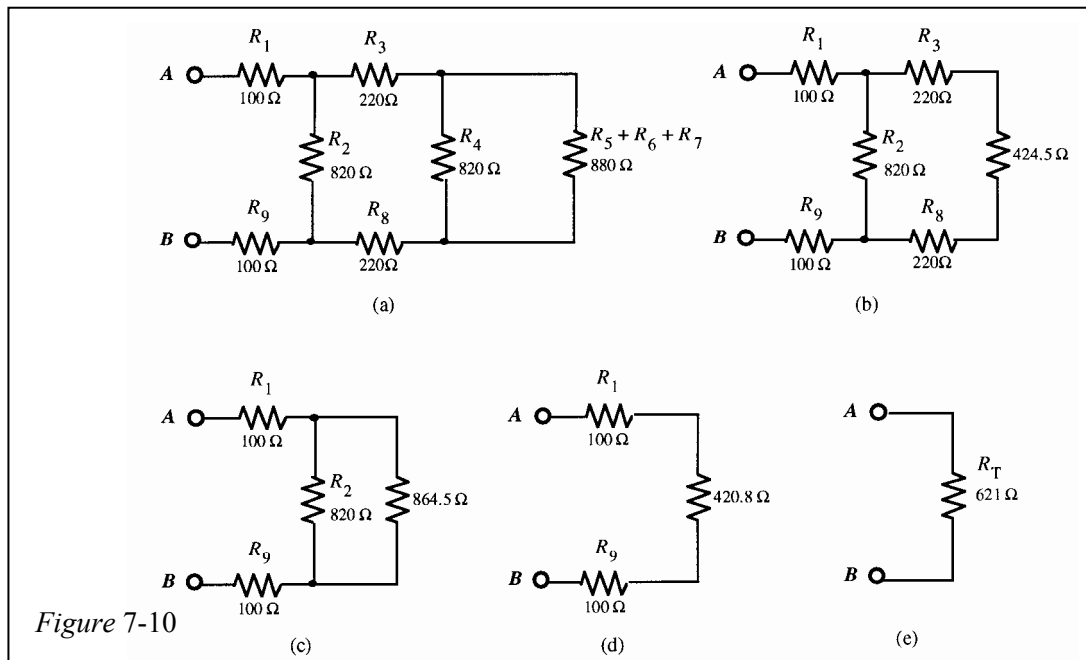

42. The currents were found in Problem 41.

$$V_1 = I_T R_1 = (16.1 \text{ mA})(100 \Omega) = 1.61 \text{ V}$$

$$V_2 = I_2 R_2 = (8.27 \text{ mA})(820 \Omega) = 6.78 \text{ V}$$

$$V_3 = I_3 R_3 = (7.84 \text{ mA})(220 \Omega) = 1.73 \text{ V}$$

$$V_4 = I_4 R_4 = (4.06 \text{ mA})(820 \Omega) = 3.33 \text{ V}$$

$$V_5 = I_5 R_5 = (3.78 \text{ mA})(100 \Omega) = 0.378 \text{ V}$$

$$V_6 = I_6 R_6 = (3.78 \text{ mA})(680 \Omega) = 2.57 \text{ V}$$

$$V_7 = I_7 R_7 = (3.78 \text{ mA})(100 \Omega) = 0.378 \text{ V}$$

$$V_8 = I_8 R_8 = (7.84 \text{ mA})(220 \Omega) = 1.73 \text{ V}$$

$$V_9 = I_9 R_9 = (16.1 \text{ mA})(100 \Omega) = 1.61 \text{ V}$$

43. The two parallel ladder networks are identical; so, the voltage to ground from each output terminal is the same; thus,

$$V_{\text{OUT}} = 0 \text{ V.}$$

Working from the right end, R_T and then I_T are determined as follows:

$$(12 \Omega + 12 \Omega) \parallel 18 \Omega = 10.3 \Omega$$

$$(22 \Omega + 10.3 \Omega) \parallel 27 \Omega = 14.7 \Omega$$

$$R_{T1} = 47 \Omega + 14.7 \Omega = 61.7 \Omega$$

$$R_{T(\text{both})} = \frac{R_{T1}}{2} = \frac{61.7 \Omega}{2} = 30.9 \Omega$$

$$I_T = \frac{30 \text{ V}}{30.9 \Omega} = 971 \text{ mA}$$

44. (a) $V_{\text{OUT}} = \frac{V}{8} = \frac{12 \text{ V}}{8} = 1.5 \text{ V}$

(b) $V_{\text{OUT}} = \frac{V}{16} = \frac{12 \text{ V}}{16} = 0.75 \text{ V}$

45. (a) $V_{\text{OUT}} = \frac{V}{4} + \frac{V}{2} = \frac{12 \text{ V}}{4} + \frac{12 \text{ V}}{2} = 3 \text{ V} + 6 \text{ V} = 9 \text{ V}$

(b) $V_{\text{OUT}} = \frac{V}{4} + \frac{V}{16} = \frac{12 \text{ V}}{4} + \frac{12 \text{ V}}{16} = 3 \text{ V} + 0.75 \text{ V} = 3.75 \text{ V}$

(c) $V_{\text{OUT}} = \frac{V}{2} + \frac{V}{4} + \frac{V}{8} + \frac{V}{16} = \frac{12 \text{ V}}{2} + \frac{12 \text{ V}}{4} + \frac{12 \text{ V}}{8} + \frac{12 \text{ V}}{16}$
 $= 6 \text{ V} + 3 \text{ V} + 1.5 \text{ V} + 0.75 \text{ V} = 11.25 \text{ V}$

Section 7-6 The Wheatstone Bridge

46. $R_x = R_y \left(\frac{R_2}{R_4} \right) = (18 \text{ k}\Omega)(0.02) = 360 \Omega$

47. $V_{\text{LEFT}} = \left(\frac{\text{SG3}}{\text{SG1} + \text{SG3}} \right) V_s = \left(\frac{119.94 \Omega}{120.06 \Omega + 119.94 \Omega} \right) 12 \text{ V} = 5.997 \text{ V}$

$$V_{\text{RIGHT}} = \left(\frac{\text{SG4}}{\text{SG2} + \text{SG4}} \right) V_s = \left(\frac{120.06 \Omega}{119.94 \Omega + 120.06 \Omega} \right) 12 \text{ V} = 6.003 \text{ V}$$

$$V_{\text{OUT}} = V_{\text{RIGHT}} - V_{\text{LEFT}} = 6.003 \text{ V} - 5.997 \text{ V} = 6 \text{ mV}$$

(Right side positive with respect to left side)

48. At 60° C , $R_{\text{THERM}} = 5 \text{ k}\Omega$

$$V_{\text{LEFT}} = \left(\frac{R_3}{R_1 + R_3} \right) V_s = \left(\frac{27 \text{ k}\Omega}{32 \text{ k}\Omega} \right) 9 \text{ V} = 7.59 \text{ V}$$

$$V_{\text{RIGHT}} = \left(\frac{R_4}{R_2 + R_4} \right) V_s = \left(\frac{27 \text{ k}\Omega}{54 \text{ k}\Omega} \right) 9 \text{ V} = 4.50 \text{ V}$$

$$V_{\text{OUT}} = V_{\text{LEFT}} - V_{\text{RIGHT}} = 7.59 \text{ V} - 4.50 \text{ V} = 3.09 \text{ V}$$

Chapter 7

Section 7-7 Troubleshooting

$$49. \quad R_{\text{eq}} = \frac{(680 \, \Omega)(4.7 \, \text{k}\Omega)}{680 \, \Omega + 4.7 \, \text{k}\Omega} = 594 \, \Omega$$

$$R_T = 560 \, \Omega + 470 \, \Omega + 594 \, \Omega = 1624 \, \Omega$$

The voltmeter reading should be

$$V_? = \left(\frac{594 \, \Omega}{1624 \, \Omega} \right) 12 \, \text{V} = 4.39 \, \text{V}$$

The voltmeter reading of 6.2 V is **incorrect**.

50. The circuit is redrawn in figure 7-11 and points are labeled.

$$R_{BG} = \frac{(10 \, \text{k}\Omega + 47 \, \text{k}\Omega)(100 \, \text{k}\Omega)}{10 \, \text{k}\Omega + 47 \, \text{k}\Omega + 100 \, \text{k}\Omega} = 36.3 \, \text{k}\Omega$$

$$R_{AG} = 33 \, \text{k}\Omega + R_{BG} = 33 \, \text{k}\Omega + 36.3 \, \text{k}\Omega = 69.3 \, \text{k}\Omega$$

$$R_T = 27 \, \text{k}\Omega + R_{AG} = 27 \, \text{k}\Omega + 69.3 \, \text{k}\Omega = 96.3 \, \text{k}\Omega$$

$$V_{AG} = \left(\frac{R_{AG}}{R_T} \right) 18 \, \text{V} = \left(\frac{69.3 \, \text{k}\Omega}{96.3 \, \text{k}\Omega} \right) 18 \, \text{V} = 12.95 \, \text{V}$$

$$V_{CG} = \left(\frac{47 \, \text{k}\Omega}{57 \, \text{k}\Omega} \right) V_{BG} = \left(\frac{47 \, \text{k}\Omega}{57 \, \text{k}\Omega} \right) 6.79 \, \text{V} = 5.60 \, \text{V}$$

$$V_{AC} = V_{AG} - V_{CG} = 12.95 \, \text{V} - 5.60 \, \text{V} = 7.35 \, \text{V}$$

Both meters are correct.

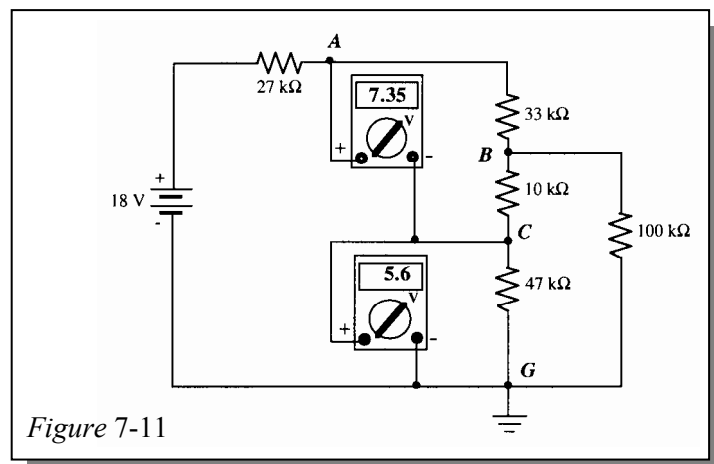

51. The 2.5 V reading indicated on one of the meters shows that the series-parallel branch containing the other meter is open. The 0 V reading on the other meter shows that there is no current in that branch. Therefore, if only one resistor is open, it must be the **2.2 kΩ**.

52. The circuit is redrawn in Figure 7-12.

$$V_A = \left(\frac{12 \text{ k}\Omega \parallel 12 \text{ k}\Omega}{12 \text{ k}\Omega \parallel 12 \text{ k}\Omega + 10 \text{ k}\Omega} \right) 150 \text{ V} = \left(\frac{6 \text{ k}\Omega}{16 \text{ k}\Omega} \right) 150 \text{ V} = 56.25 \text{ V}$$

The meter reading of 81.8 V is **incorrect**.

The most likely fault is an open 12 kΩ resistor. This will cause the voltage at point A to be higher than it should be. To verify, calculate V_A assuming an open 12 kΩ resistor.

$$V_A = \left(\frac{12 \text{ k}\Omega}{22 \text{ k}\Omega} \right) 150 \text{ V} = 81.8 \text{ V}$$

$$V_B = \left(\frac{2.2 \text{ k}\Omega}{7.8 \text{ k}\Omega} \right) 150 \text{ V} = 42.3 \text{ V}$$

The meter is **correct**.

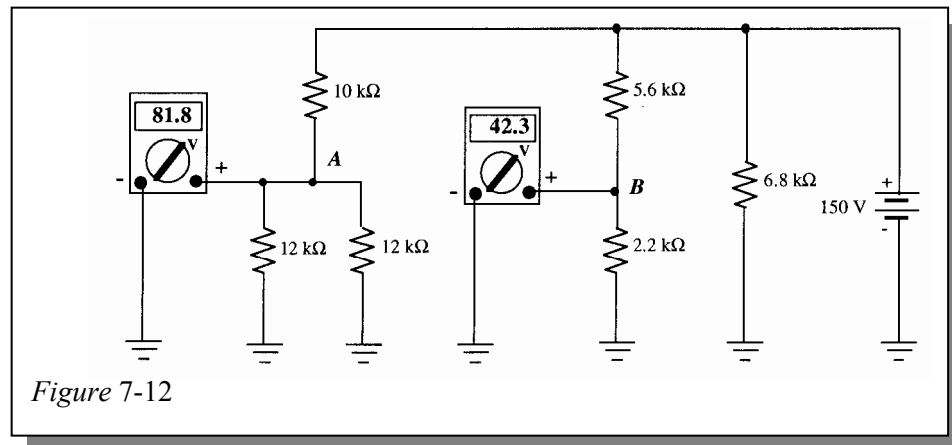

Figure 7-12

53. $V_{3.3 \text{ k}\Omega} = \left(\frac{1.62 \text{ k}\Omega}{2.62 \text{ k}\Omega} \right) (-10 \text{ V}) = -6.18 \text{ V}$

The -7.62 V reading is incorrect.

$$V_{2.2 \text{ k}\Omega} = \left(\frac{2.2 \text{ k}\Omega}{3.2 \text{ k}\Omega} \right) (-6.18 \text{ V}) = -4.25$$

The -5.24 V reading is incorrect.

The 3.3 kΩ resistor must be open. If it is, then

$$V_{3.3 \text{ k}\Omega} = \left(\frac{3.2 \text{ k}\Omega}{4.2 \text{ k}\Omega} \right) (-10 \text{ V}) = -7.62 \text{ V}$$

$$V_{2.2 \text{ k}\Omega} = \left(\frac{2.2 \text{ k}\Omega}{3.2 \text{ k}\Omega} \right) (-7.62 \text{ V}) = -5.24 \text{ V}$$

54. If R_2 opens, $V_A = 15 \text{ V}$, $V_B = 0 \text{ V}$, and $V_C = 0 \text{ V}$

Multisim Troubleshooting and Analysis

55. $R_T = 296.744 \Omega$ 56. R_4 is open. 57. $R_3 = 560 \text{ k}\Omega$
 58. No fault. 59. R_5 is shorted. 60. $R_X = 550 \Omega$

Chapter 8

Circuit Theorems and Conversions

Note: Solutions show conventional current direction.

Section 8-3 Source Conversions

$$1. \quad I_S = \frac{V_S}{R_S} = \frac{300 \text{ V}}{50 \Omega} = 6 \text{ A}$$

$$R_S = 50 \Omega$$

See Figure 8-1.

$$2. \quad (a) \quad I_S = \frac{5 \text{ kV}}{100 \Omega} = 50 \text{ A}$$

$$(b) \quad I_S = \frac{12 \text{ V}}{2.2 \Omega} = 5.45 \text{ A}$$

$$3. \quad R_S = \frac{1.6 \text{ V}}{8.0 \text{ A}} = 0.2 \Omega$$

4. See Figure 8-2.

$$5. \quad V_S = I_S R_S = (600 \text{ mA})(1.2 \text{ k}\Omega) = 720 \text{ V}$$

$$R_S = 1.2 \text{ k}\Omega$$

See Figure 8-3.

$$6. \quad (a) \quad V_S = (10 \text{ mA})(4.7 \text{ k}\Omega) = 47 \text{ V}$$

$$(b) \quad V_S = (0.01 \text{ A})(2.7 \text{ k}\Omega) = 27 \text{ V}$$

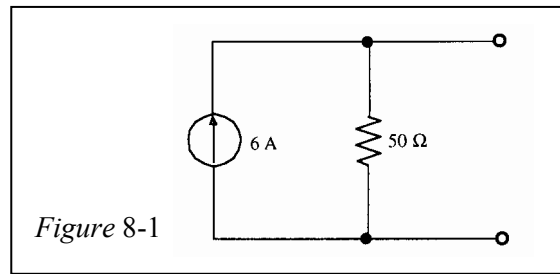

Figure 8-1

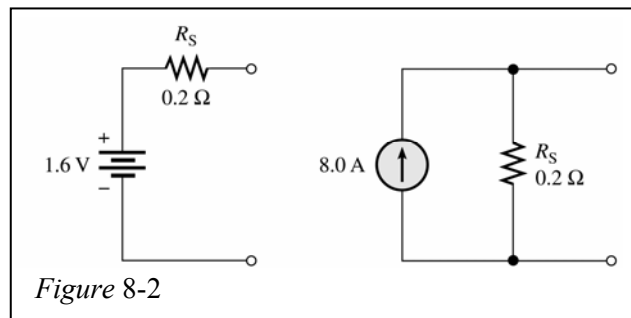

Figure 8-2

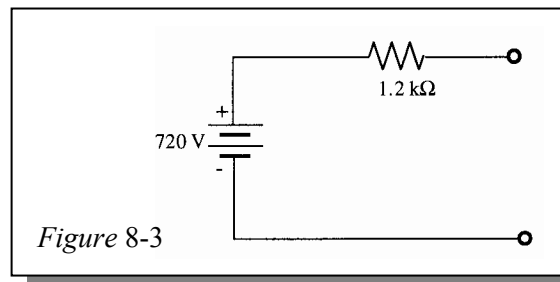

Figure 8-3

Section 8-4 The Superposition Theorem

7. First, zero the 3 V source by replacing it with a short as in Figure 8-4(a).

$$R_T = 1.955 \text{ k}\Omega$$

$$I_T = \frac{2 \text{ V}}{1.955 \text{ k}\Omega} = 1.02 \text{ mA}$$

$$I_3 = \left(\frac{2.2 \text{ k}\Omega}{3.89 \text{ k}\Omega} \right) 1.02 \text{ mA} = 577 \mu\text{A}$$

$$I_5 = \left(\frac{1 \text{ k}\Omega}{3.2 \text{ k}\Omega} \right) 5.77 \text{ }\mu\text{A} = 180 \text{ }\mu\text{A}$$

Next, zero the 2 V source by replacing it with a short as in Figure 8-4(b).

$$R_T = 1.955 \text{ k}\Omega$$

$$I_T = \frac{3 \text{ V}}{1.955 \text{ k}\Omega} = 1.53 \text{ mA}$$

$$I_5 = \left(\frac{1.69 \text{ k}\Omega}{3.89 \text{ k}\Omega} \right) 1.53 \text{ mA} = 655 \text{ }\mu\text{A}$$

Since both components of I_5 are in the same direction, the total I_5 is

$$I_{5(\text{total})} = 180 \text{ }\mu\text{A} + 655 \text{ }\mu\text{A} = \mathbf{845 \text{ }\mu\text{A}}$$

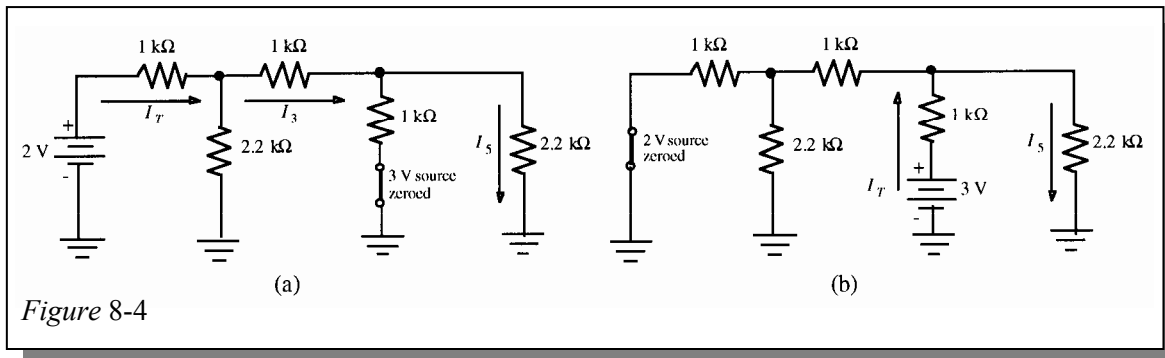

Figure 8-4

8. From Problem 7:

$$R_T = 1.955 \text{ k}\Omega \text{ and } I_T = 1.02 \text{ mA}$$

Current in R_2 due to the 2 V source acting alone. See Figure 8-5(a):

$$I_2 = \left(\frac{1.69 \text{ k}\Omega}{3.89 \text{ k}\Omega} \right) 1.02 \text{ mA} = 443 \text{ }\mu\text{A} \text{ (downward)}$$

From Problem 7:

$$R_T = 1.955 \text{ k}\Omega \text{ and } I_T = 1.53 \text{ mA}$$

Current in R_2 due to the 3 V source acting alone. See Figure 8-5(b):

$$I_{\text{Left}} = \left(\frac{2.2 \text{ k}\Omega}{3.89 \text{ k}\Omega} \right) 1.53 \text{ mA} = 865 \text{ }\mu\text{A}$$

$$I_2 = \left(\frac{1 \text{ k}\Omega}{3.2 \text{ k}\Omega} \right) 865 \text{ }\mu\text{A} = 270 \text{ }\mu\text{A} \text{ (downward)}$$

The total current through R_2 is

$$I_2 = 443 \text{ }\mu\text{A} + 270 \text{ }\mu\text{A} = \mathbf{713 \text{ }\mu\text{A}}$$

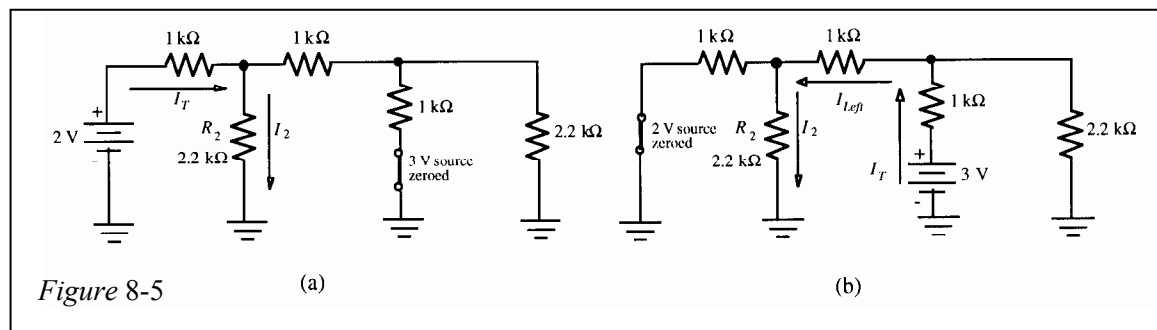

Figure 8-5

Chapter 8

9. First, zero the voltage source by replacing it with a short as shown in Figure 8-6(a):

$$I_1 = \left(\frac{680 \Omega}{852.6 \Omega} \right) 100 \text{ mA} = 79.8 \text{ mA}$$

$$I_3 = \left(\frac{220 \Omega}{1020 \Omega} \right) 79.8 \text{ mA} = 17.2 \text{ mA}$$

Next, zero the current source by replacing it with an open as shown in Figure 8-6(b):

$$R_T = 587.6 \Omega$$

$$I_T = \frac{20 \text{ V}}{587.6 \Omega} = 34.0 \text{ mA}$$

$$I_3 = \left(\frac{680 \Omega}{1480 \Omega} \right) 34.0 \text{ mA} = 15.6 \text{ mA}$$

The total I_3 is the difference of the two component currents found in the above steps because they are in opposite directions.

$$I_{3(\text{total})} = 17.2 \text{ mA} - 15.6 \text{ mA} = \mathbf{1.6 \text{ mA}}$$

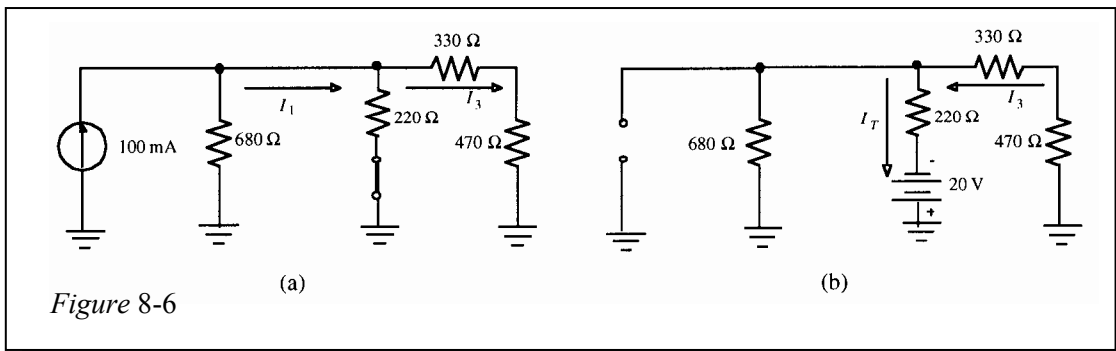

10. (a) Current through R_L due to the 1 A source. See Figure 8-7(a):

$$I_L = \left(\frac{2.2 \text{ k}\Omega}{6.1 \text{ k}\Omega} \right) 1 \text{ A} = 361 \text{ mA (down)}$$

Current through R_L due to the 2 A source is zero because of infinite resistance (open) of the 1 A source. See Figure 8-7(b):

$$I_L = 0 \text{ A}$$

Total current through R_L :

$$I_{L(\text{total})} = 361 \text{ mA} + 0 \text{ A} = 361 \text{ mA}$$

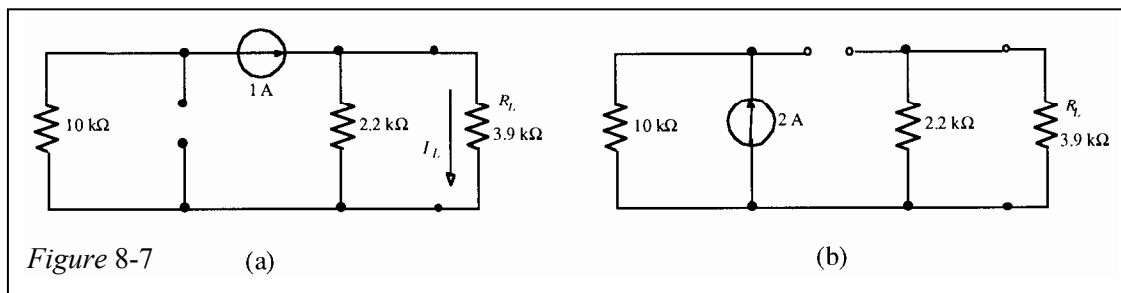

- (b) Current through R_L due to the 40 V source is zero because of zero resistance (short) of the 60 V source. See Figure 8-8(a):

$$I_L = 0 \text{ A}$$

Current through R_L due to the 0.5 A source is zero because of zero resistance of the 60 V source. See Figure 8-8(b):

$$I_L = 0 \text{ A}$$

Current through R_L due to the 60 V source. See Figure 8-8(c):

$$V_L = \left(\frac{1.5 \text{ k}\Omega}{2.06 \text{ k}\Omega} \right) 60 \text{ V} = 43.7 \text{ V}$$

$$I_L = \frac{V_L}{R_L} = \frac{43.7 \text{ V}}{1.5 \text{ k}\Omega} = 29.1 \text{ mA}$$

Total current through R_L :

$$I_L = 0 \text{ A} + 0 \text{ A} + 29.1 \text{ mA} = \mathbf{29.1 \text{ mA}}$$

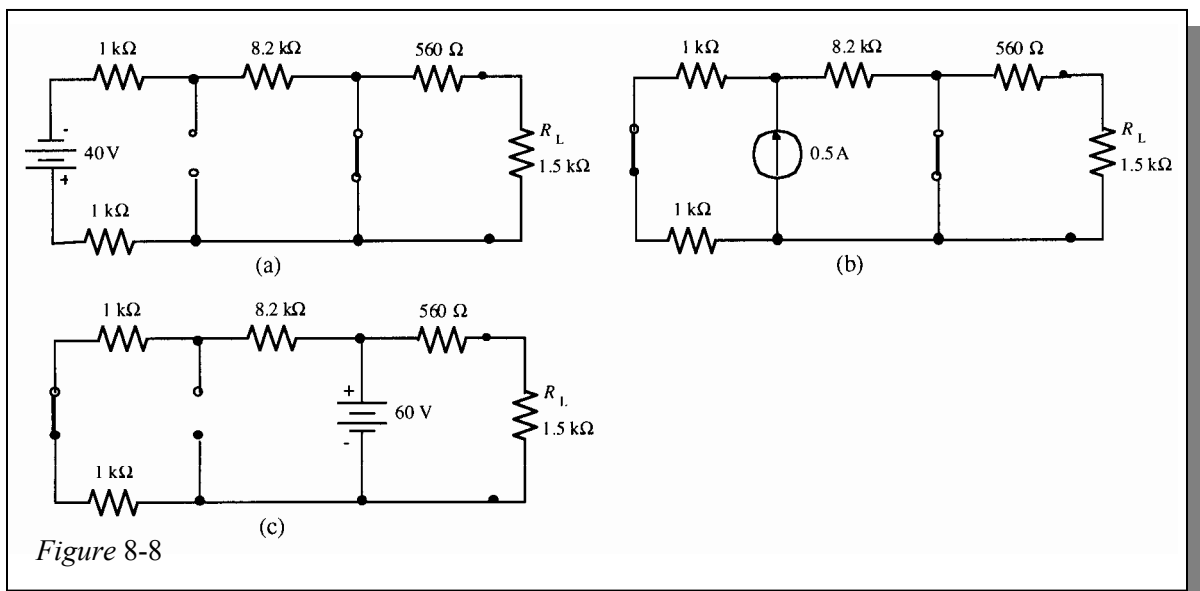

$$11. \quad V_{\text{Ref(max)}} = \left(\frac{R_2 + R_3}{R_1 + R_2 + R_3} \right) 30 \text{ V} - 15 \text{ V} = \left(\frac{7.8 \text{ k}\Omega}{12.5 \text{ k}\Omega} \right) 30 \text{ V} - 15 \text{ V} = \mathbf{3.72 \text{ V}}$$

$$V_{\text{Ref(min)}} = \left(\frac{R_3}{R_1 + R_2 + R_3} \right) 30 \text{ V} - 15 \text{ V} = \left(\frac{6.8 \text{ k}\Omega}{12.5 \text{ k}\Omega} \right) 30 \text{ V} - 15 \text{ V} = \mathbf{1.32 \text{ V}}$$

Chapter 8

$$12. \quad V_{\text{Ref(max)}} = \left(\frac{R_2 + R_3}{R_1 + R_2 + R_3} \right) 30 \text{ V} - 15 \text{ V} = \left(\frac{16.8 \text{ k}\Omega}{21.5 \text{ k}\Omega} \right) 30 \text{ V} - 15 \text{ V} = \mathbf{8.44 \text{ V}}$$

$$V_{\text{Ref(min)}} = \left(\frac{R_3}{R_1 + R_2 + R_3} \right) 30 \text{ V} - 15 \text{ V} = \left(\frac{6.8 \text{ k}\Omega}{21.5 \text{ k}\Omega} \right) 30 \text{ V} - 15 \text{ V} = \mathbf{-5.51 \text{ V}}$$

13. 75 V source. See Figure 8-9(a):

$$R_{\text{eq}} = R_2 \parallel R_3 \parallel (R_4 + R_5) = 17.2 \text{ k}\Omega$$

$$V_A = \left(\frac{R_{\text{eq}}}{R_{\text{eq}} + R_1} \right) 75 \text{ V} = \left(\frac{17.2 \text{ k}\Omega}{99.2 \text{ k}\Omega} \right) 75 \text{ V} = 13 \text{ V}$$

$$V_B = \left(\frac{R_5}{R_4 + R_5} \right) V_A = \left(\frac{91 \text{ k}\Omega}{101 \text{ k}\Omega} \right) 13 \text{ V} = 11.7 \text{ V}$$

50 V source. See Figure 8-9(b):

$$R_{\text{eq}} = R_1 \parallel R_2 \parallel (R_4 + R_5) = 25 \text{ k}\Omega$$

$$V_A = - \left(\frac{R_{\text{eq}}}{R_{\text{eq}} + R_3} \right) 50 \text{ V} = - \left(\frac{25 \text{ k}\Omega}{58 \text{ k}\Omega} \right) 50 \text{ V} = -21.6 \text{ V}$$

$$V_B = \left(\frac{R_5}{R_4 + R_5} \right) V_A = \left(\frac{91 \text{ k}\Omega}{101 \text{ k}\Omega} \right) (-21.6 \text{ V}) = -19.5 \text{ V}$$

100 V source. See Figure 8-9(c):

$$R_{\text{eq}} = R_1 \parallel R_2 \parallel R_3 = 16.6 \text{ k}\Omega$$

$$R_T = 10 \text{ k}\Omega + 91 \text{ k}\Omega + 16.6 \text{ k}\Omega = 117.6 \text{ k}\Omega$$

$$I_T = \frac{100 \text{ V}}{117.6 \text{ k}\Omega} = 850 \mu\text{A}$$

$$V_A = (850 \mu\text{A})(16.6 \text{ k}\Omega) = 14.1 \text{ V}$$

$$V_B = -(850 \mu\text{A})(91 \text{ k}\Omega) = -77.4 \text{ V}$$

Superimposing voltages at each point:

$$V_A = 13 \text{ V} - 21.6 \text{ V} + 14.1 \text{ V} = 5.5 \text{ V}$$

$$V_B = 11.7 \text{ V} - 19.5 \text{ V} - 77.4 \text{ V} = -85.2 \text{ V}$$

$$V_{AB} = 5.5 \text{ V} - (-85.2 \text{ V}) = \mathbf{90.7 \text{ V}}$$

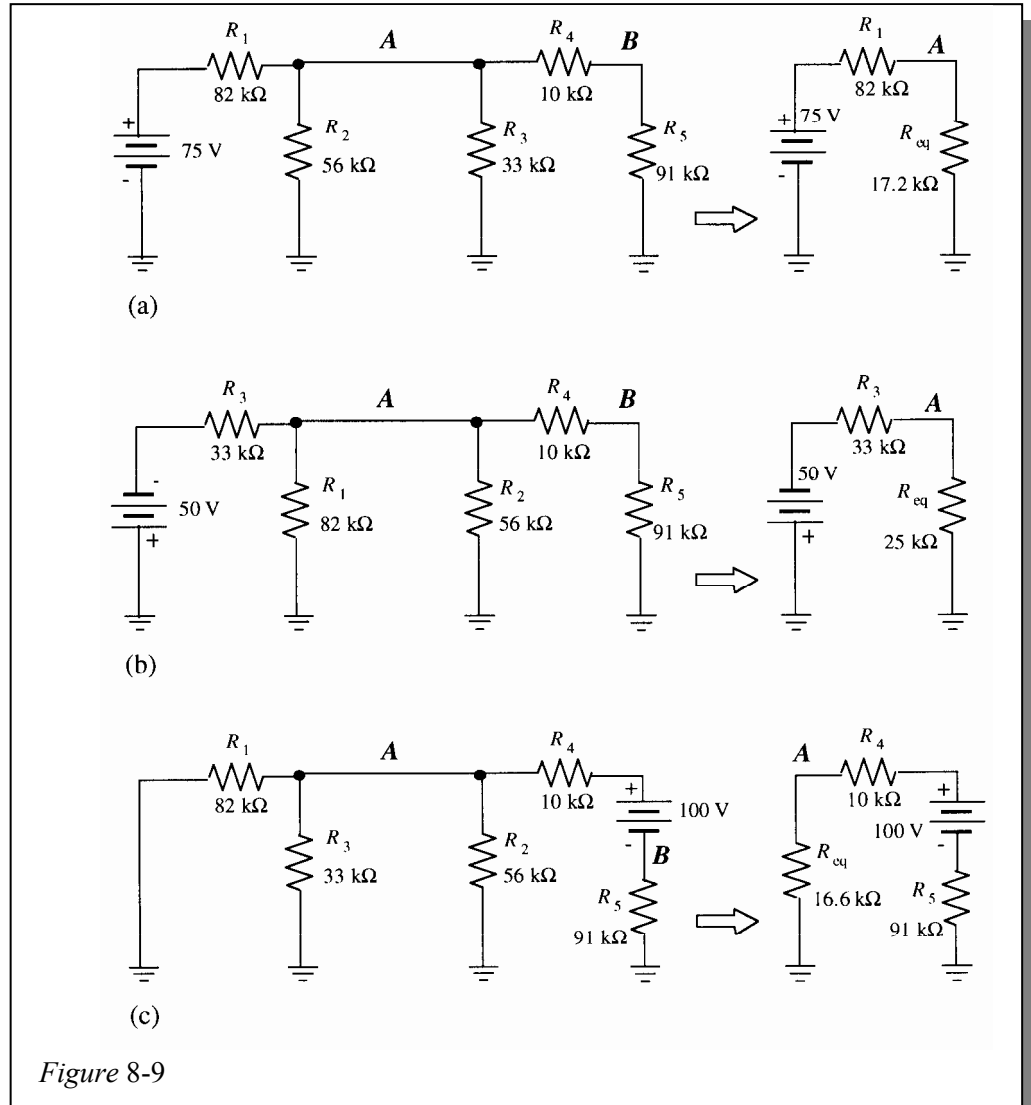

Figure 8-9

Chapter 8

14. SW1 closed. See Figure 8-10(a):

$$I_L = \frac{12 \text{ V}}{5.6 \text{ k}\Omega + 18 \text{ k}\Omega} = \frac{12 \text{ V}}{23.6 \text{ k}\Omega} = 508 \text{ }\mu\text{A}$$

SW1 and SW2 closed. See Figure 8-10(b):

Current from the 12 V source (6 V source zeroed)

$$R_T = R_1 + R_2 \parallel R_L = 5.6 \text{ k}\Omega + 8.2 \text{ k}\Omega \parallel 18 \text{ k}\Omega = 11.2 \text{ k}\Omega$$

$$I_T = \frac{12 \text{ V}}{11.2 \text{ k}\Omega} = 1.07 \text{ mA}$$

$$I_L = \left(\frac{8.2 \text{ k}\Omega}{26.2 \text{ k}\Omega} \right) 1.07 \text{ mA} = 335 \text{ }\mu\text{A}$$

Current from the 6 V source (12 V source zeroed):

$$R_T = R_2 + R_1 \parallel R_L = 8.2 \text{ k}\Omega + 5.6 \text{ k}\Omega \parallel 18 \text{ k}\Omega = 12.47 \text{ k}\Omega$$

$$I_T = \frac{6 \text{ V}}{12.47 \text{ k}\Omega} = 481 \text{ }\mu\text{A}$$

$$I_L = \left(\frac{5.6 \text{ k}\Omega}{23.6 \text{ k}\Omega} \right) 481 \text{ }\mu\text{A} = 114 \text{ }\mu\text{A}$$

$$I_{L(\text{total})} = 335 \text{ }\mu\text{A} + 114 \text{ }\mu\text{A} = 449 \text{ }\mu\text{A}$$

SW1, SW2, and SW3 closed. See Figure 8-10(c).

Current from the 12 V source (6 V and 9 V sources zeroed):

$$R_T = R_1 + R_2 \parallel R_3 \parallel R_L = 5.6 \text{ k}\Omega + 8.2 \text{ k}\Omega \parallel 12 \text{ k}\Omega \parallel 18 \text{ k}\Omega = 9.43 \text{ k}\Omega$$

$$I_T = \frac{12 \text{ V}}{9.43 \text{ k}\Omega} = 1.27 \text{ mA}$$

$$I_L = \left(\frac{R_2 \parallel R_3 \parallel R_L}{R_L} \right) I_T = \left(\frac{3.83 \text{ k}\Omega}{18 \text{ k}\Omega} \right) 1.27 \text{ mA} = 270 \text{ }\mu\text{A}$$

Current from the 6 V source (9 V and 12 V sources zeroed):

$$R_T = R_2 + R_1 \parallel R_3 \parallel R_L = 8.2 \text{ k}\Omega + 5.6 \text{ k}\Omega \parallel 12 \text{ k}\Omega \parallel 18 \text{ k}\Omega = 11.35 \text{ k}\Omega$$

$$I_T = \frac{6 \text{ V}}{11.35 \text{ k}\Omega} = 529 \text{ }\mu\text{A}$$

$$I_L = \left(\frac{R_1 \parallel R_3 \parallel R_L}{R_L} \right) I_T = \left(\frac{3.15 \text{ k}\Omega}{18 \text{ k}\Omega} \right) 529 \text{ }\mu\text{A} = 93 \text{ }\mu\text{A}$$

Current from the 9 V source (6 V and 12 V sources zeroed):

$$R_T = R_3 + R_1 \parallel R_2 \parallel R_L = 12 \text{ k}\Omega + 5.6 \text{ k}\Omega \parallel 8.2 \text{ k}\Omega \parallel 18 \text{ k}\Omega = 14.8 \text{ k}\Omega$$

$$I_T = \frac{9 \text{ V}}{14.85 \text{ k}\Omega} = 608 \text{ }\mu\text{A}$$

$$I_L = \left(\frac{R_1 \parallel R_2 \parallel R_L}{R_L} \right) I_T = \left(\frac{2.81 \text{ k}\Omega}{18 \text{ k}\Omega} \right) 608 \text{ }\mu\text{A} = 95 \text{ }\mu\text{A}$$

$$I_{L(\text{total})} = 270 \text{ }\mu\text{A} + 93 \text{ }\mu\text{A} + 95 \text{ }\mu\text{A} = 458 \text{ }\mu\text{A}$$

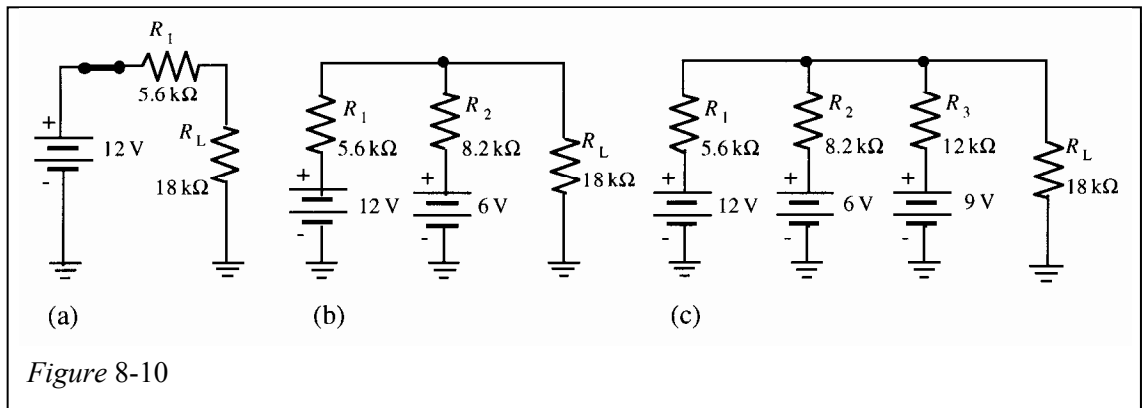

Figure 8-10

15. V_{S1} “sees” a total resistance of

$$\begin{aligned}
 R_T &= 10 \text{ k}\Omega + (5.6 \text{ k}\Omega \parallel (10 \text{ k}\Omega + (5.6 \text{ k}\Omega \parallel ((10 \text{ k}\Omega + 5.6 \text{ k}\Omega) \\
 &\quad + (10 \text{ k}\Omega \parallel (5.6 \text{ k}\Omega + (10 \text{ k}\Omega \parallel 5.6 \text{ k}\Omega)))))) \\
 &= 10 \text{ k}\Omega + (5.6 \text{ k}\Omega \parallel (10 \text{ k}\Omega + (5.6 \text{ k}\Omega \parallel (15.6 \text{ k}\Omega + (10 \text{ k}\Omega \parallel (5.6 \text{ k}\Omega + 3.59 \text{ k}\Omega)))))) \\
 &= 10 \text{ k}\Omega + (5.6 \text{ k}\Omega \parallel (10 \text{ k}\Omega + (5.6 \text{ k}\Omega \parallel (15.6 \text{ k}\Omega + (10 \text{ k}\Omega \parallel 9.19 \text{ k}\Omega)))))) \\
 &= 10 \text{ k}\Omega + (5.6 \text{ k}\Omega \parallel (10 \text{ k}\Omega + (5.6 \text{ k}\Omega \parallel (15.6 \text{ k}\Omega + 4.79 \text{ k}\Omega)))) \\
 &= 10 \text{ k}\Omega + (5.6 \text{ k}\Omega \parallel (10 \text{ k}\Omega + (5.6 \text{ k}\Omega \parallel 20.4 \text{ k}\Omega))) \\
 &= 10 \text{ k}\Omega + (5.6 \text{ k}\Omega \parallel (10 \text{ k}\Omega + 4.39 \text{ k}\Omega)) \\
 &= 10 \text{ k}\Omega + (5.6 \text{ k}\Omega \parallel (14.4 \text{ k}\Omega)) = 10 \text{ k}\Omega + 4.03 \text{ k}\Omega = 14.0 \text{ k}\Omega
 \end{aligned}$$

$$I_{T(S1)} = \frac{32 \text{ V}}{14.0 \text{ k}\Omega} = \mathbf{2.28 \text{ mA}}$$

- V_{S2} “sees” a total resistance of

$$\begin{aligned}
 R_T &= 5.6 \text{ k}\Omega + (10 \text{ k}\Omega \parallel (5.6 \text{ k}\Omega + (10 \text{ k}\Omega \parallel ((10 \text{ k}\Omega + 5.6 \text{ k}\Omega) \\
 &\quad + (5.6 \text{ k}\Omega \parallel (10 \text{ k}\Omega + (5.6 \text{ k}\Omega \parallel 10 \text{ k}\Omega)))))) \\
 &= 5.6 \text{ k}\Omega + (10 \text{ k}\Omega \parallel (5.6 \text{ k}\Omega + (10 \text{ k}\Omega \parallel (15.6 \text{ k}\Omega + (5.6 \text{ k}\Omega \parallel (10 \text{ k}\Omega + 3.59 \text{ k}\Omega)))))) \\
 &= 5.6 \text{ k}\Omega + (10 \text{ k}\Omega \parallel (5.6 \text{ k}\Omega + (10 \text{ k}\Omega \parallel (15.6 \text{ k}\Omega + (5.6 \text{ k}\Omega \parallel 13.6 \text{ k}\Omega)))))) \\
 &= 5.6 \text{ k}\Omega + (10 \text{ k}\Omega \parallel (5.6 \text{ k}\Omega + (10 \text{ k}\Omega \parallel (15.6 \text{ k}\Omega + (3.97 \text{ k}\Omega)))))) \\
 &= 5.6 \text{ k}\Omega + (10 \text{ k}\Omega \parallel (5.6 \text{ k}\Omega + (10 \text{ k}\Omega \parallel (19.6 \text{ k}\Omega)))) \\
 &= 5.6 \text{ k}\Omega + (10 \text{ k}\Omega \parallel (5.6 \text{ k}\Omega + 6.62 \text{ k}\Omega)) \\
 &= 5.6 \text{ k}\Omega + (10 \text{ k}\Omega \parallel 12.2 \text{ k}\Omega) = 5.6 \text{ k}\Omega + 550 \text{ k}\Omega = 11.1 \text{ k}\Omega
 \end{aligned}$$

$$I_{T(S2)} = \frac{15 \text{ V}}{11.1 \text{ k}\Omega} = \mathbf{1.35 \text{ mA}}$$

Chapter 8

Section 8-5 Thevenin's Theorem

16. (a) $R_{TH} = 27\ \Omega + 75\ \Omega \parallel 147\ \Omega = 76.7\ \Omega$
 $V_{TH} = \left(\frac{75\ \Omega}{222\ \Omega} \right) 25\ \text{V} = 8.45\ \text{V}$
- (b) $R_{TH} = 100\ \Omega \parallel 270\ \Omega = 73\ \Omega$
 $V_{TH} = \left(\frac{100\ \Omega}{370\ \Omega} \right) 3\ \text{V} = 811\ \text{mV}$
- (c) $R_{TH} = 56\ \text{k}\Omega \parallel 100\ \text{k}\Omega = 35.9\ \text{k}\Omega$
 $V_{TH} = \left(\frac{56\ \text{k}\Omega}{156\ \text{k}\Omega} \right) (15\ \text{V} - 10\ \text{V}) = 1.79\ \text{V}$
- (b) $R_{TH} = 2.2\ \text{k}\Omega \parallel (1\ \text{k}\Omega + 2.2\ \text{k}\Omega) = 1.3\ \text{k}\Omega$
 $I_{AB} = \left(\frac{2.2\ \text{k}\Omega}{5.4\ \text{k}\Omega} \right) 0.1\ \text{A} = 40.7\ \text{mA}$
 $V_{TH} = I_{AB}(2.2\ \text{k}\Omega)$
 $= (40.7\ \text{mA})(2.2\ \text{k}\Omega) = 89.5\ \text{V}$

17. First, convert the circuit to its Thevenin equivalent as shown in the steps of Figure 8-11.

$$R_{TH} = 13.97\ \text{k}\Omega$$

$$V_A = \left(\frac{4.12\ \text{k}\Omega}{14.12\ \text{k}\Omega} \right) 32\ \text{V} = 9.34\ \text{V}$$

$$V_{TH} = \left(\frac{5.6\ \text{k}\Omega}{15.6\ \text{k}\Omega} \right) V_A = \left(\frac{5.6\ \text{k}\Omega}{15.6\ \text{k}\Omega} \right) 9.34\ \text{V} = 3.35\ \text{V}$$

$$I_L = \frac{V_{TH}}{R_{TH} + R_L} = \frac{3.35\ \text{V}}{28.97\ \text{k}\Omega} = 116\ \mu\text{A}$$

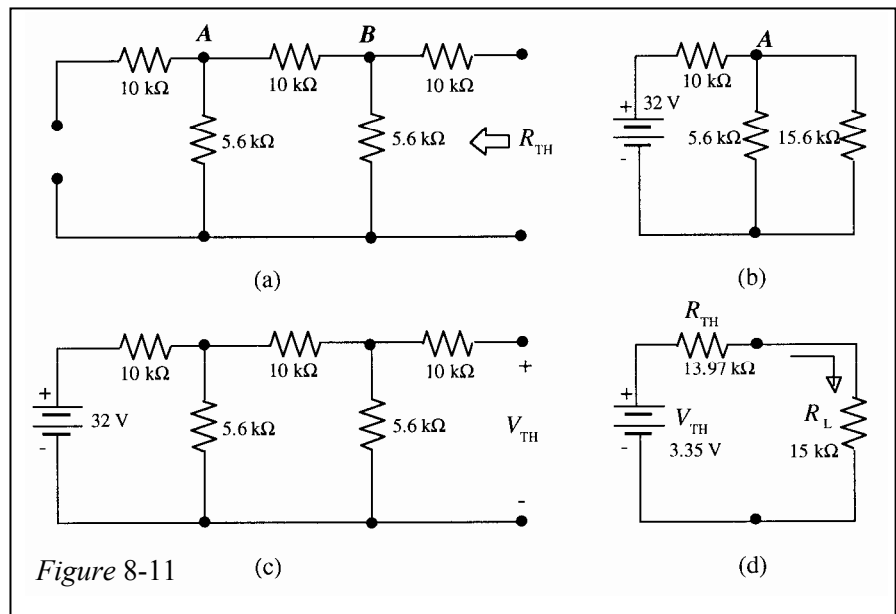

18. First, zero (open) the current source, remove R_4 , and redraw the circuit as shown in Figure 8-12(a).

$$R_{TH} = R_3 \parallel (R_1 + R_2 \parallel R_5) = 5.6 \text{ k}\Omega \parallel (1 \text{ k}\Omega + 1.65 \text{ k}\Omega) = 5.6 \text{ k}\Omega \parallel 2.65 \text{ k}\Omega = 1.8 \text{ k}\Omega$$

$$V_{TH} = \left(\frac{2.65 \text{ k}\Omega}{5.6 \text{ k}\Omega + 2.65 \text{ k}\Omega} \right) 50 \text{ V} = \left(\frac{2.65 \text{ k}\Omega}{8.25 \text{ k}\Omega} \right) 50 \text{ V} = 16.1 \text{ V}$$

Determine V_4 due to the 50 V source using the Thevenin circuit in Figure 8-12(b).

$$V_4 = \left(\frac{R_4}{R_{TH} + R_4} \right) V_{TH} = \left(\frac{10 \text{ k}\Omega}{11.8 \text{ k}\Omega} \right) 16.1 \text{ V} = 13.6 \text{ V}$$

Next, zero (short) the voltage source, remove R_4 , and redraw the circuit as shown in Figure 8-12(c).

$$R_{TH} = R_3 \parallel (R_1 + R_2 \parallel R_5) = 5.6 \text{ k}\Omega \parallel (1 \text{ k}\Omega + 1.65 \text{ k}\Omega) = 5.6 \text{ k}\Omega \parallel 2.65 \text{ k}\Omega = 1.8 \text{ k}\Omega$$

$$I_3 = \left(\frac{2.65 \text{ k}\Omega}{8.25 \text{ k}\Omega} \right) 10 \text{ mA} = 3.2 \text{ mA}$$

$$V_{TH} = V_3 = I_3 R_3 = (3.2 \text{ mA})(5.6 \text{ k}\Omega) = 17.9 \text{ V}$$

Determine V_4 due to the current source using the Thevenin circuit in Figure 8-12(d).

$$V_4 = \left(\frac{R_4}{R_{TH} + R_4} \right) V_{TH} = \left(\frac{10 \text{ k}\Omega}{11.8 \text{ k}\Omega} \right) 17.9 \text{ V} = 15.2 \text{ V}$$

Use superposition to combine the V_4 voltages to get the total voltage across R_4 :

$$V_4 = 13.6 \text{ V} + 15.2 \text{ V} = \mathbf{28.8 \text{ V}}$$

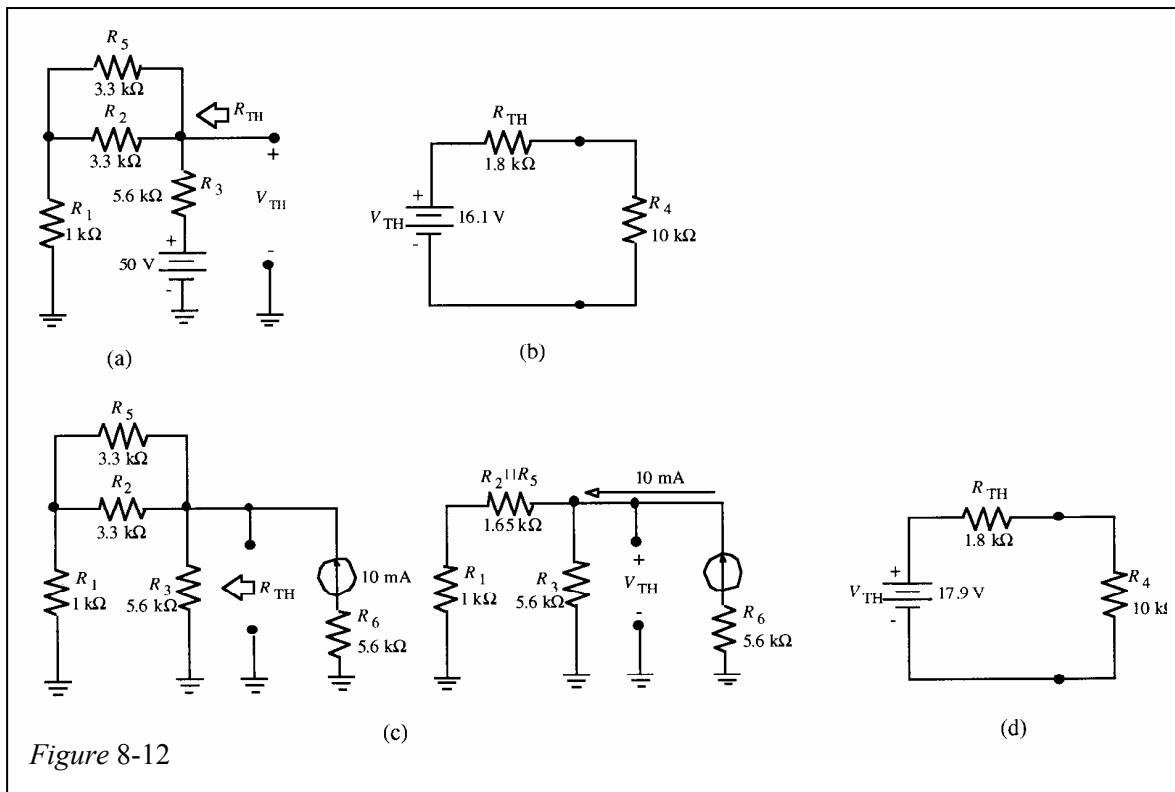

Figure 8-12

Chapter 8

19. Looking back from the amplifier input:

$$R_{TH} = R_1 \parallel R_2 \parallel R_3 = 100 \Omega \parallel 2.2 \text{ k}\Omega \parallel 1.2 \text{ k}\Omega = \mathbf{88.6 \Omega}$$

1 V source (Figure 8-13(a)):

$$V_A = \left(\frac{776 \Omega}{876 \Omega} \right) 1 \text{ V} = 886 \text{ mV}$$

5 V source (Figure 8-13(b)):

$$V_A = \left(\frac{92.3 \Omega}{2292 \Omega} \right) 5 \text{ V} = 200 \text{ mV}$$

$$V_{TH} = 886 \text{ mV} + 200 \text{ mV} = \mathbf{1.09 \text{ V}}$$

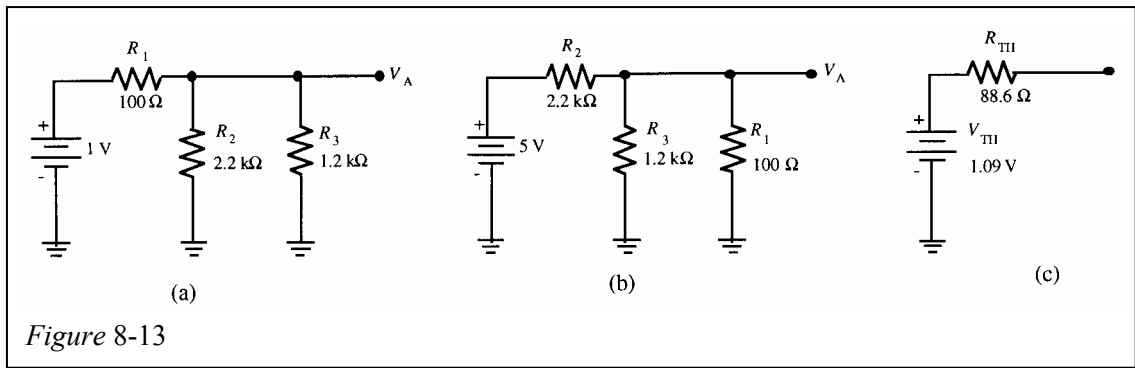

20. Consider $R_6 \parallel (R_7 + R_8)$ to be the load. Thevenize to the left of point A as shown in Figure 8-14(a).

$$R_{TH} = R_5 + R_4 \parallel (R_3 + (R_1 \parallel R_2)) = 1 \text{ k}\Omega + 4.7 \text{ k}\Omega \parallel (10 \text{ k}\Omega + 6.8 \text{ k}\Omega \parallel 9.1 \text{ k}\Omega)$$

$$= 1 \text{ k}\Omega + 4.7 \text{ k}\Omega \parallel 13.89 \text{ k}\Omega = 4.51 \text{ k}\Omega$$

See Figure 8-14(b) to determine V_{TH} :

$$R_T = (R_3 + R_4) \parallel R_2 + R_1 = (10 \text{ k}\Omega + 4.7 \text{ k}\Omega) \parallel 6.8 \text{ k}\Omega + 9.1 \text{ k}\Omega = 4.65 \text{ k}\Omega + 9.1 \text{ k}\Omega = 13.8 \text{ k}\Omega$$

$$I_T = \frac{48 \text{ V}}{13.8 \text{ k}\Omega} = 3.48 \text{ mA}$$

$$I_4 = \left(\frac{R_2}{R_2 + R_3 + R_4} \right) I_T = \left(\frac{6.8 \text{ k}\Omega}{21.5 \text{ k}\Omega} \right) 3.48 \text{ mA} = 1.1 \text{ mA}$$

$$V_4 = I_4 R_4 = (1.1 \text{ mA})(4.7 \text{ k}\Omega) = 5.17 \text{ V}$$

$$V_X = 48 \text{ V} - V_4 = 48 \text{ V} - 5.17 \text{ V} = 42.8 \text{ V}$$

$$V_{TH} = V_A = V_X = 42.8 \text{ V}$$

The Thevenin circuit is shown in Figure 8-14(c). The current into point *A* is determined for each value of R_8 .

When $R_8 = 1 \text{ k}\Omega$:

$$R_L = 12 \text{ k}\Omega \parallel (8.2 \text{ k}\Omega + 1 \text{ k}\Omega) = 5.21 \text{ k}\Omega$$

$$I_A = \frac{V_{TH}}{R_{TH} + R_L} = \frac{42.8 \text{ V}}{9.72 \text{ k}\Omega} = \mathbf{4.41 \text{ mA}}$$

When $R_8 = 5 \text{ k}\Omega$:

$$R_L = 12 \text{ k}\Omega \parallel (8.2 \text{ k}\Omega + 5 \text{ k}\Omega) = 6.29 \text{ k}\Omega$$

$$I_A = \frac{V_{TH}}{R_{TH} + R_L} = \frac{42.8 \text{ V}}{10.8 \text{ k}\Omega} = \mathbf{3.97 \text{ mA}}$$

When $R_8 = 10 \text{ k}\Omega$:

$$R_L = 12 \text{ k}\Omega \parallel (8.2 \text{ k}\Omega + 10 \text{ k}\Omega) = 7.23 \text{ k}\Omega$$

$$I_A = \frac{V_{TH}}{R_{TH} + R_L} = \frac{42.8 \text{ V}}{11.7 \text{ k}\Omega} = \mathbf{3.66 \text{ mA}}$$

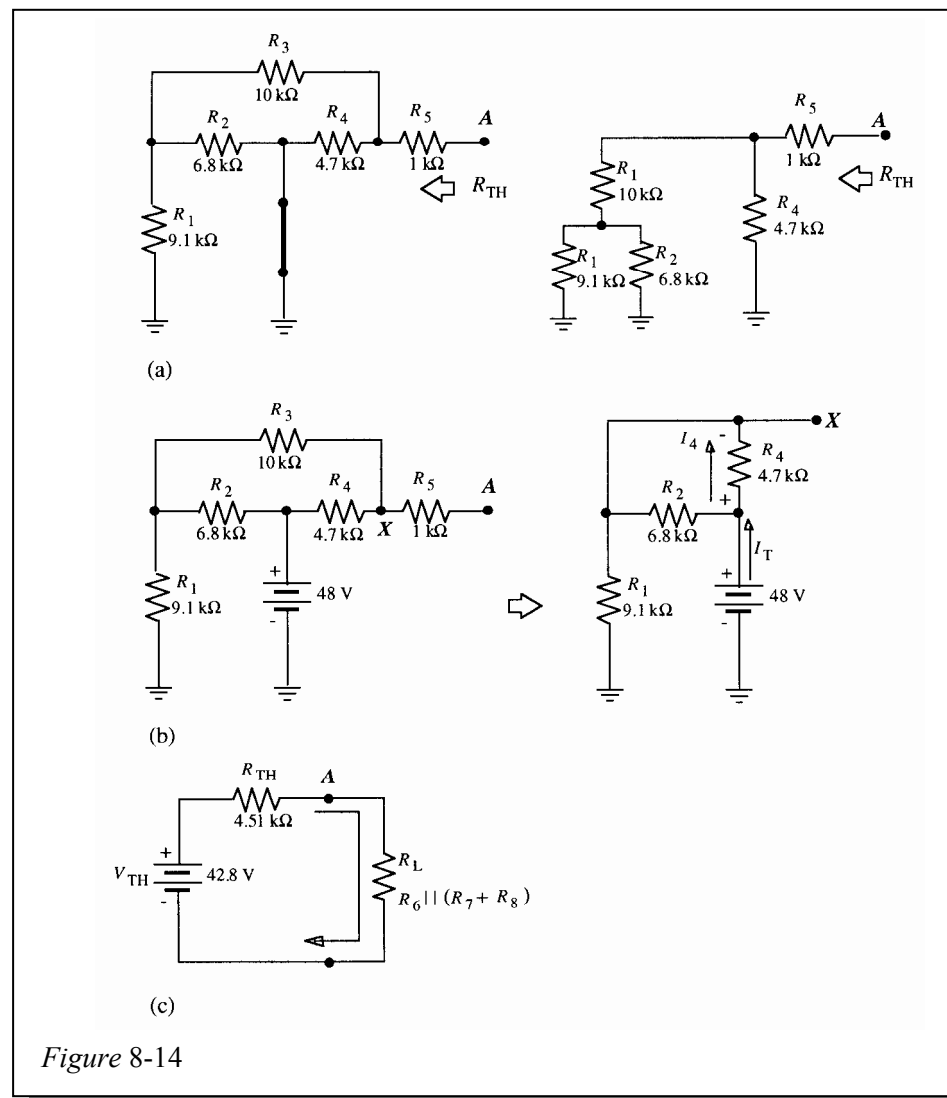

Chapter 8

21. See Figure 8-15.

$$V_{TH} = V_A - V_B = \left(\frac{2.2 \text{ k}\Omega}{3.2 \text{ k}\Omega} \right) 12 \text{ V} - \left(\frac{1.2 \text{ k}\Omega}{2.02 \text{ k}\Omega} \right) 12 \text{ V} = 8.25 \text{ V} - 7.13 \text{ V} = 1.12 \text{ V}$$

$$R_{TH} = 1 \text{ k}\Omega \parallel 2.2 \text{ k}\Omega + 820 \Omega \parallel 1.2 \text{ k}\Omega = 688 \Omega + 487 \Omega = 1175 \Omega$$

$$I_L = \frac{V_{TH}}{R_{TH} + R_L} = \frac{1.12 \text{ V}}{11,175 \Omega} = \mathbf{100 \mu\text{A}}$$

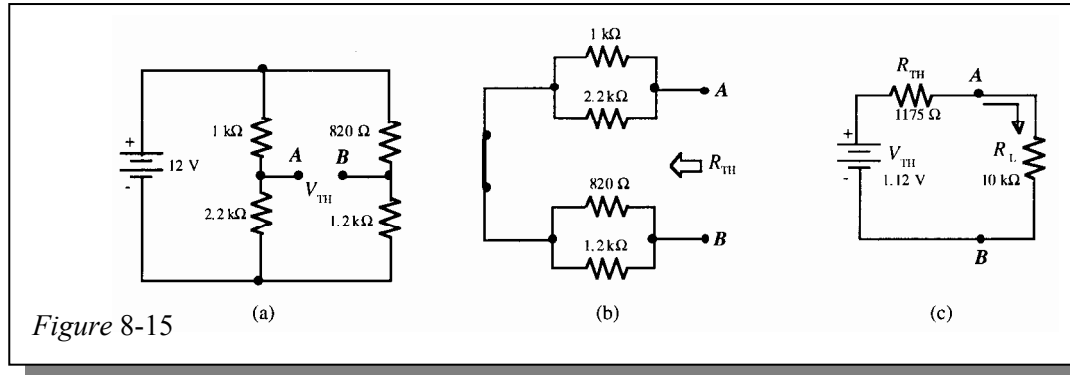

22. See Figure 8-16.

$$V_{R3} = (0.2 \text{ mA})(15 \text{ k}\Omega) = 3 \text{ V}$$

$$R_4 = \frac{V_S - V_{R3}}{I_4} = \frac{10 \text{ V} - 3 \text{ V}}{0.2 \text{ mA}} = 35 \text{ k}\Omega$$

$$V_A = \left(\frac{R_2}{R_1 + R_2} \right) V_S = \left(\frac{12 \text{ k}\Omega}{22 \text{ k}\Omega} \right) 10 \text{ V} = 5.46 \text{ V}$$

$$V_B = \left(\frac{R_4}{R_3 + R_4} \right) V_S = \left(\frac{35 \text{ k}\Omega}{50 \text{ k}\Omega} \right) 10 \text{ V} = 7 \text{ V}$$

$$V_{TH} = V_{BA} = V_B - V_A = 7 \text{ V} - 5.46 \text{ V} = \mathbf{1.54 \text{ V}}$$

$$R_{TH} = R_1 \parallel R_2 + R_3 \parallel R_4 = 5.46 \text{ k}\Omega + 10.5 \text{ k}\Omega = \mathbf{15.96 \text{ k}\Omega}$$

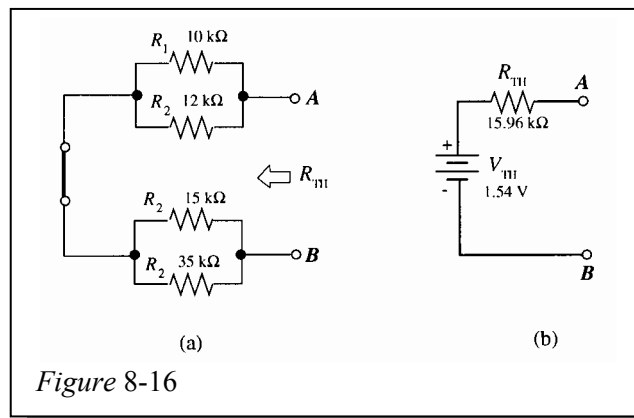

Figure 8-16

Section 8-6 Norton's Theorem

23. (a) See Figure 8-17(a).

$$R_N = 76.7 \Omega$$

$$R_T = 166.9 \Omega$$

$$I_T = \frac{25 \text{ V}}{166.9 \Omega} = 150 \text{ mA}$$

$$I_N = \left(\frac{75 \Omega}{102 \Omega} \right) I_T = \left(\frac{75 \Omega}{102 \Omega} \right) 150 \text{ mA} = 110 \text{ mA}$$

(b) See Figure 8-17(b).

$$R_N = 73 \Omega$$

$$I_N = \frac{3 \text{ V}}{270 \Omega} = 11.1 \text{ mA}$$

(c) See Figure 8-17(c).

$$R_N = \frac{(56 \text{ k}\Omega)(100 \text{ k}\Omega)}{156 \text{ k}\Omega} = 35.9 \text{ k}\Omega$$

$$I_N = \frac{5 \text{ V}}{100 \text{ k}\Omega} = 50 \mu\text{A}$$

(d) See Figure 8-17(d).

$$R_N = \frac{(3.2 \text{ k}\Omega)(2.2 \text{ k}\Omega)}{5.4 \text{ k}\Omega} = 1.3 \text{ k}\Omega$$

$$I_N = \left(\frac{2.2 \text{ k}\Omega}{3.2 \text{ k}\Omega} \right) 0.1 \text{ A} = 68.8 \text{ mA}$$

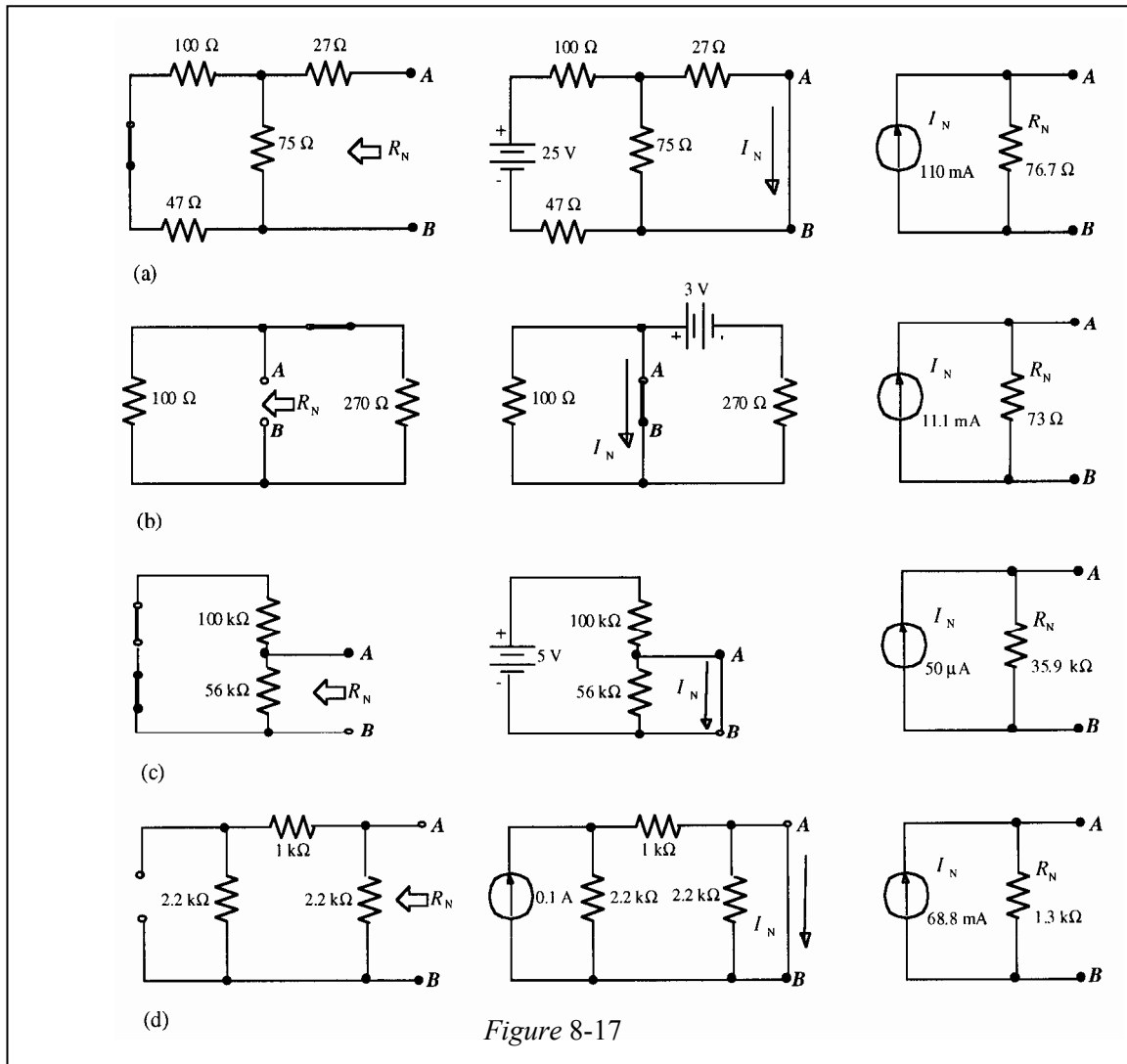

Figure 8-17

Chapter 8

24. First, R_N is found by circuit simplification as shown in Figure 8-18(a).

$$R_N = 14.0 \text{ k}\Omega$$

The current I_N through the shorted AB terminals is found as shown in Figure 8-18 (b).

$$R_T = 14.0 \text{ k}\Omega \text{ as viewed from the source}$$

$$I_T = \frac{32 \text{ V}}{14.0 \text{ k}\Omega} = 2.29 \text{ mA}$$

$$I_1 = \left(\frac{5.6 \text{ k}\Omega}{19.2 \text{ k}\Omega} \right) 2.29 \text{ mA} = 668 \text{ }\mu\text{A}$$

$$I_N = \left(\frac{5.6 \text{ k}\Omega}{15.6 \text{ k}\Omega} \right) 668 \text{ }\mu\text{A} = 240 \text{ }\mu\text{A}$$

Finally, the current through R_L is determined by connecting R_L to the Norton equivalent circuit as shown in Figure 8-18(c).

$$I_L = \left(\frac{14.0 \text{ k}\Omega}{29.0 \text{ k}\Omega} \right) 240 \text{ }\mu\text{A} = \mathbf{116 \text{ }\mu\text{A}}$$

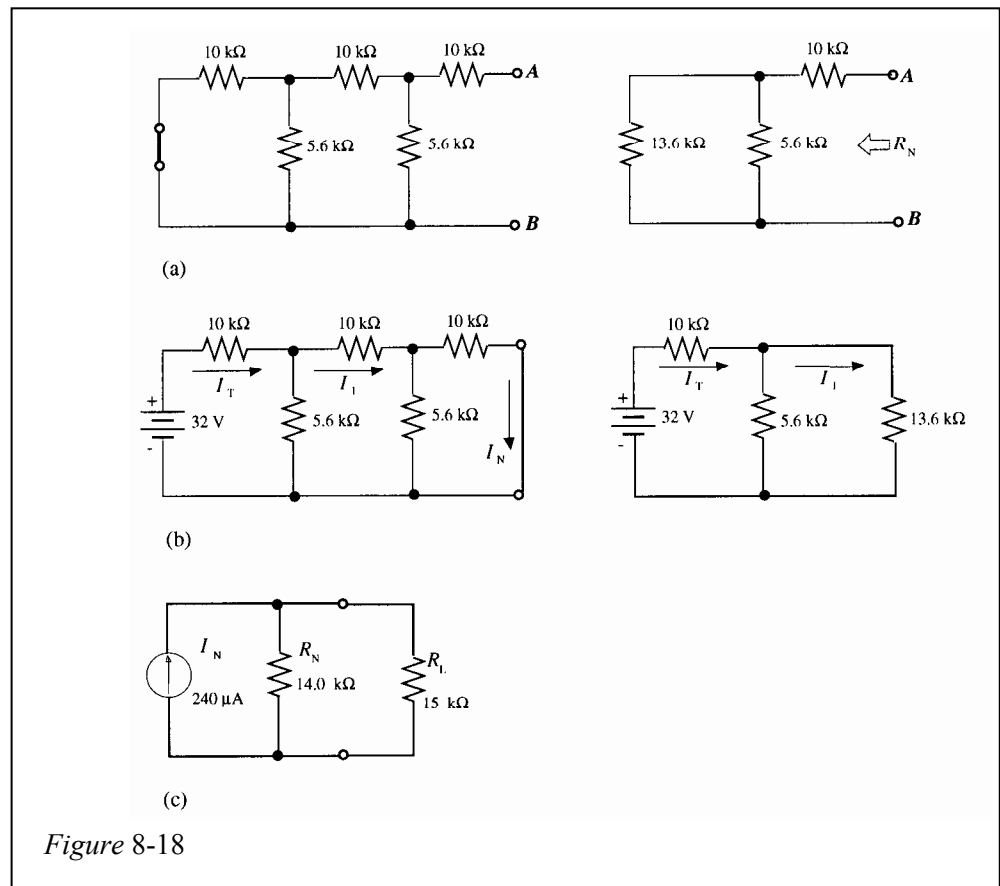

Figure 8-18

25. The 50 V source acting alone. Short AB to get I_N . See Figure 8-19(a):

$$R_T = R_3 + R_1 \parallel R_4 = 5.6 \text{ k}\Omega + 1 \text{ k}\Omega \parallel 10 \text{ k}\Omega = 6.51 \text{ k}\Omega$$

$$I_T = \frac{50 \text{ V}}{6.51 \text{ k}\Omega} = 7.68 \text{ mA}$$

$$I_N = \left(\frac{R_4}{R_1 + R_4} \right) I_T = \left(\frac{10 \text{ k}\Omega}{11 \text{ k}\Omega} \right) 7.68 \text{ mA} = 6.98 \text{ mA}$$

See Figure 8-19(b):

$$R_N = R_2 \parallel (R_1 + R_3 \parallel R_4) = 3.3 \text{ k}\Omega \parallel (1 \text{ k}\Omega + 5.6 \text{ k}\Omega \parallel 10 \text{ k}\Omega) = 3.3 \text{ k}\Omega \parallel 4.59 \text{ k}\Omega = 1.92 \text{ k}\Omega$$

See Figure 8-19(c):

$$I_{R_5} = \left(\frac{R_N}{R_N + R_5} \right) I_N = \left(\frac{1.92 \text{ k}\Omega}{5.22 \text{ k}\Omega} \right) 6.98 \text{ mA} = 2.57 \text{ mA (from B to A)}$$

The 10 mA source acting alone. Short AB to get I_N . See Figure 8-19(d):

$$I_N = \left(\frac{R_3 \parallel R_4}{R_1 + R_3 \parallel R_4} \right) 10 \text{ mA} = \left(\frac{5.6 \text{ k}\Omega \parallel 10 \text{ k}\Omega}{1 \text{ k}\Omega + 5.6 \text{ k}\Omega \parallel 10 \text{ k}\Omega} \right) 10 \text{ mA} = \left(\frac{3.59 \text{ k}\Omega}{4.59 \text{ k}\Omega} \right) 10 \text{ mA} = 7.82 \text{ mA}$$

$$R_N = 1.92 \text{ k}\Omega$$

See Figure 8-19(e):

$$I_{R_5} = \left(\frac{1.9 \text{ k}\Omega}{5.22 \text{ k}\Omega} \right) 7.82 \text{ mA} = 2.85 \text{ mA (from B to A)}$$

$$V_5 = I_5 R_5 = (5.42 \text{ mA})(3.3 \text{ k}\Omega) = 17.9 \text{ V}$$

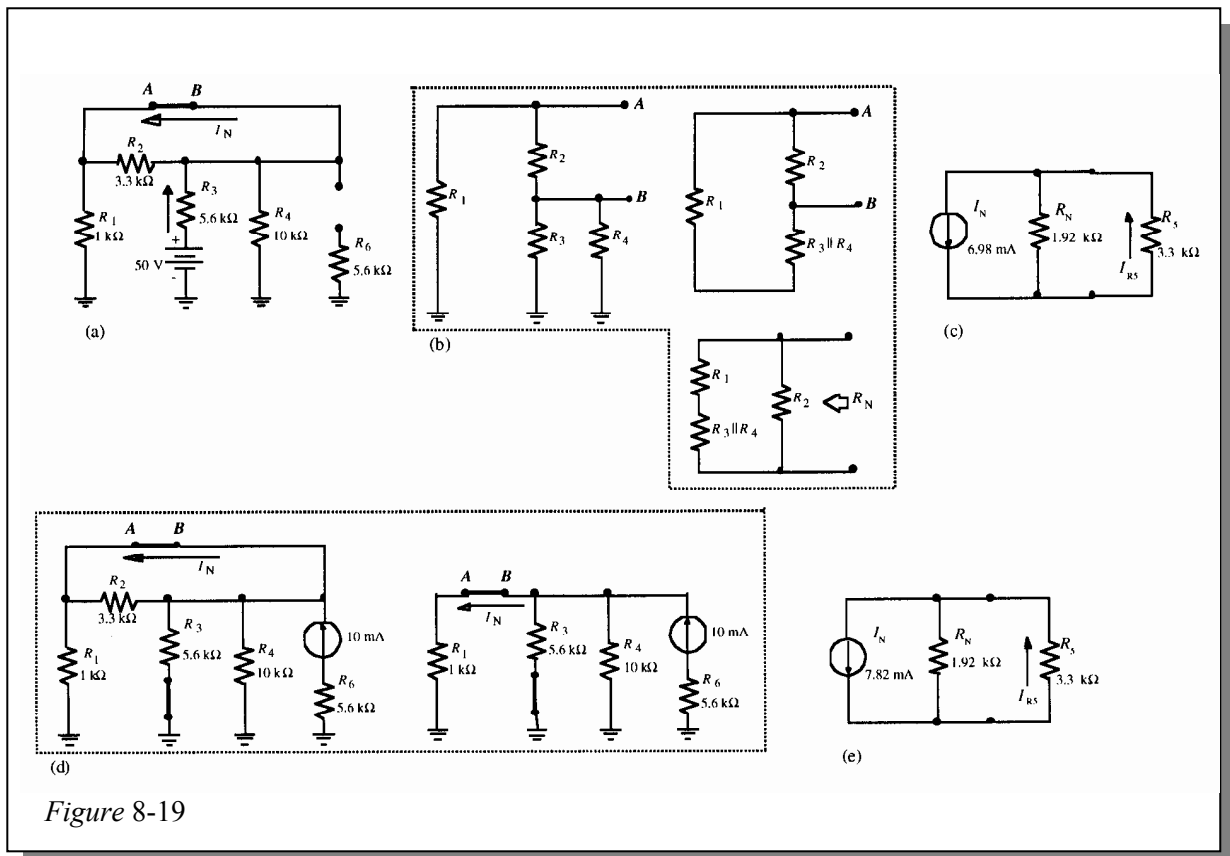

Figure 8-19

Chapter 8

26. See Figure 8-20(a):

$$\begin{aligned} R_N &= R_2 \parallel (R_3 + R_4 \parallel (R_5 + R_6 \parallel (R_7 + R_8))) \\ &= 6.8 \text{ k}\Omega \parallel (10 \text{ k}\Omega + 4.7 \text{ k}\Omega \parallel (1 \text{ k}\Omega + 6.89 \text{ k}\Omega)) \\ &= 6.8 \text{ k}\Omega \parallel (10 \text{ k}\Omega + 2.95 \text{ k}\Omega) = 4.46 \text{ k}\Omega \end{aligned}$$

See Figure 8-20(b):

$$\begin{aligned} R_T &= R_2 \parallel (R_4 + R_3 \parallel (R_5 + R_6 \parallel (R_7 + R_8))) \\ &= 6.8 \text{ k}\Omega \parallel (4.7 \text{ k}\Omega + 10 \text{ k}\Omega \parallel (1 \text{ k}\Omega + 6.89 \text{ k}\Omega)) \\ &= 6.8 \text{ k}\Omega \parallel (4.7 \text{ k}\Omega + 4.41 \text{ k}\Omega) = 3.89 \text{ k}\Omega \end{aligned}$$

$$I_T = \frac{48 \text{ V}}{3.89 \text{ k}\Omega} = 12.3 \text{ mA}$$

$$I_2 = \left(\frac{9.11 \text{ k}\Omega}{6.8 \text{ k}\Omega + 9.11 \text{ k}\Omega} \right) I_T = \left(\frac{9.11 \text{ k}\Omega}{6.8 \text{ k}\Omega + 9.11 \text{ k}\Omega} \right) 12.3 \text{ mA} = 7.07 \text{ mA}$$

$$I_4 = \left(\frac{6.8 \text{ k}\Omega}{15.9 \text{ k}\Omega} \right) 12.3 \text{ mA} = 5.27 \text{ mA}$$

$$I_3 = \left(\frac{7.89 \text{ k}\Omega}{15.9 \text{ k}\Omega} \right) 5.27 \text{ mA} = 2.62 \text{ mA}$$

$$I_N = I_2 + I_3 = 7.07 \text{ mA} + 2.62 \text{ mA} = 9.69 \text{ mA}$$

See Figure 8-20(c):

$$I_1 = \left(\frac{4.46 \text{ k}\Omega}{13.6 \text{ k}\Omega} \right) 9.69 \text{ mA} = 3.18 \text{ mA}$$

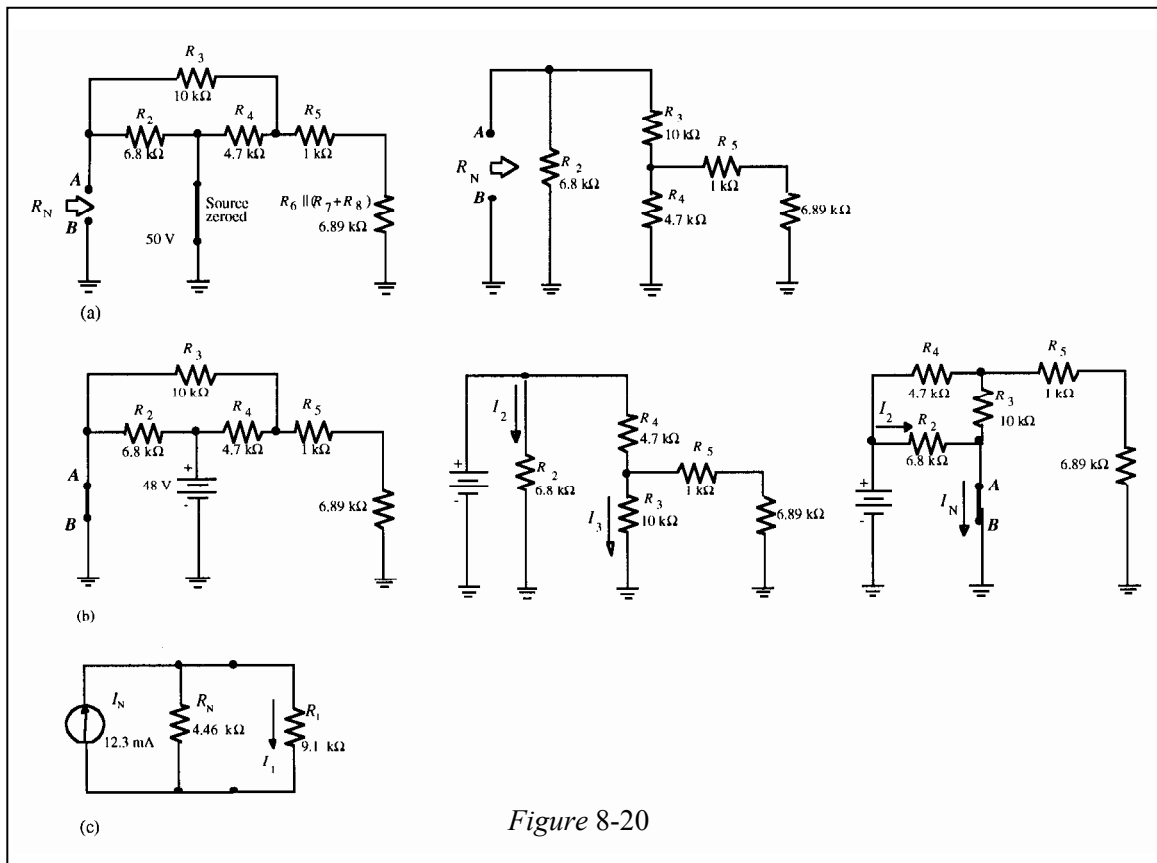

Figure 8-20

27. Using the results of Problem 21:

$$I_N = \frac{V_{TH}}{R_{TH}} = \frac{1.12 \text{ V}}{1175 \Omega} = 953 \mu\text{A}$$

$$R_N = R_{TH} = 1175 \Omega$$

See Figure 8-21.

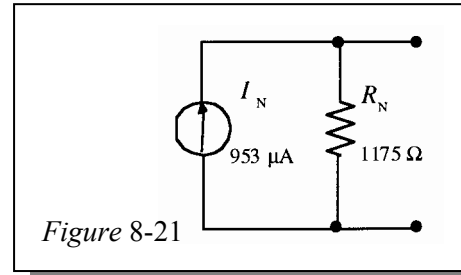

Figure 8-21

28. See Figure 8-22(a):

$$R_N = 10 \text{ k}\Omega \parallel (15 \text{ k}\Omega + 8.2 \text{ k}\Omega \parallel 22 \text{ k}\Omega) = 6.77 \text{ k}\Omega$$

See Figure 8-22(b):

$$R_T = 8.2 \text{ k}\Omega \parallel 15 \text{ k}\Omega + 22 \text{ k}\Omega = 27.3 \text{ k}\Omega$$

$$I_T = \frac{12 \text{ V}}{27.3 \text{ k}\Omega} = 440 \mu\text{A}$$

$$I_{N1} = \left(\frac{8.2 \text{ k}\Omega}{23.3 \text{ k}\Omega} \right) 440 \mu\text{A} = 156 \mu\text{A} \text{ down}$$

See Figure 8-22(c):

$$I_{N2} = \left(\frac{15 \text{ k}\Omega}{15 \text{ k}\Omega + 22 \text{ k}\Omega \parallel 8.2 \text{ k}\Omega} \right) 10 \text{ mA} = \left(\frac{15 \text{ k}\Omega}{20.97 \text{ k}\Omega} \right) 10 \text{ mA} = 7.15 \text{ mA down}$$

See Figure 8-22(d):

$$I_N = I_{N1} + I_{N2} = 156 \mu\text{A} + 7.15 \text{ mA} = 7.31 \text{ mA}$$

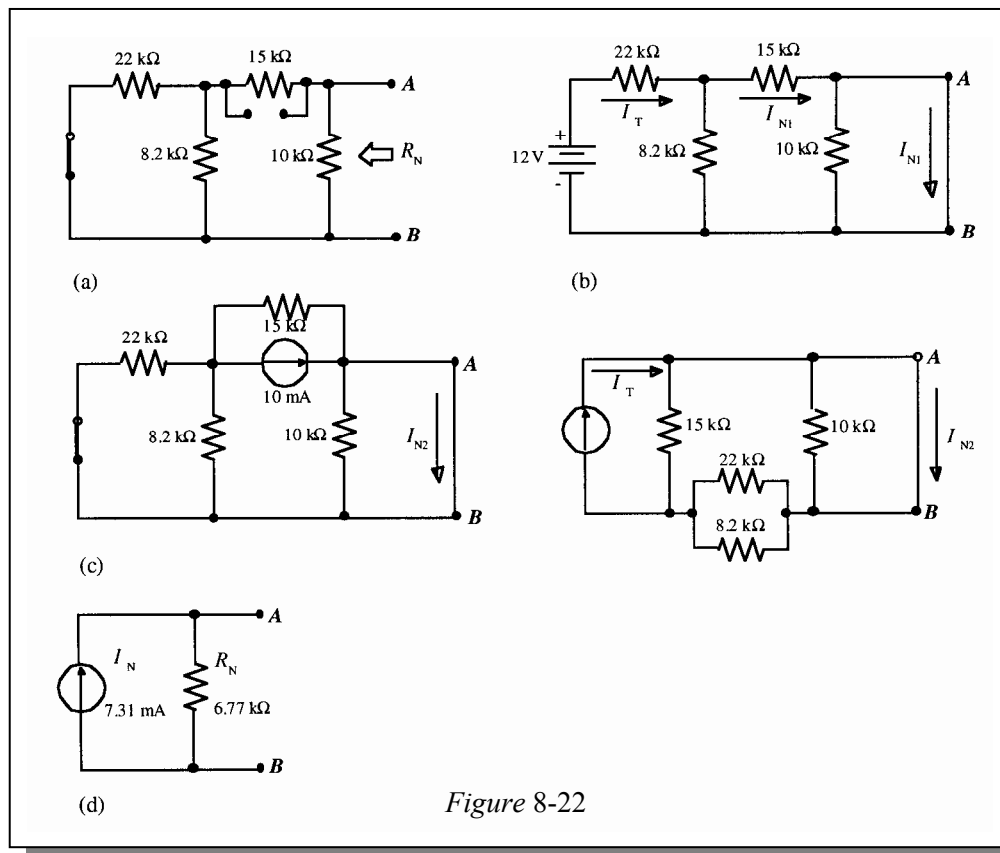

Figure 8-22

Chapter 8

29. $R_N = 220 \Omega \parallel 100 \Omega \parallel 330 \Omega = 56.9 \Omega$

Find I_{N1} due to the 3 V source, as shown in Figure 8-23(a).

$$I_{N1} = \frac{3 \text{ V}}{330 \Omega} = 9.1 \text{ mA (down)}$$

Find I_{N2} due to the 8 V source, as shown in Figure 8-23(b).

$$I_{N2} = \frac{-8 \text{ V}}{100 \Omega} = -80 \text{ mA (up)}$$

Find I_{N3} due to the 5 V source, as shown in Figure 8-23(c).

$$I_{N1} = \frac{5 \text{ V}}{220 \Omega} = 22.7 \text{ mA (down)}$$

The Norton equivalent is shown in Figure 8-23(d).

$$I_{N(\text{tot})} = I_{N1} + I_{N2} + I_{N3} = 9.1 \text{ mA} - 80 \text{ mA} + 22.7 \text{ mA} = -48.2 \text{ mA}$$

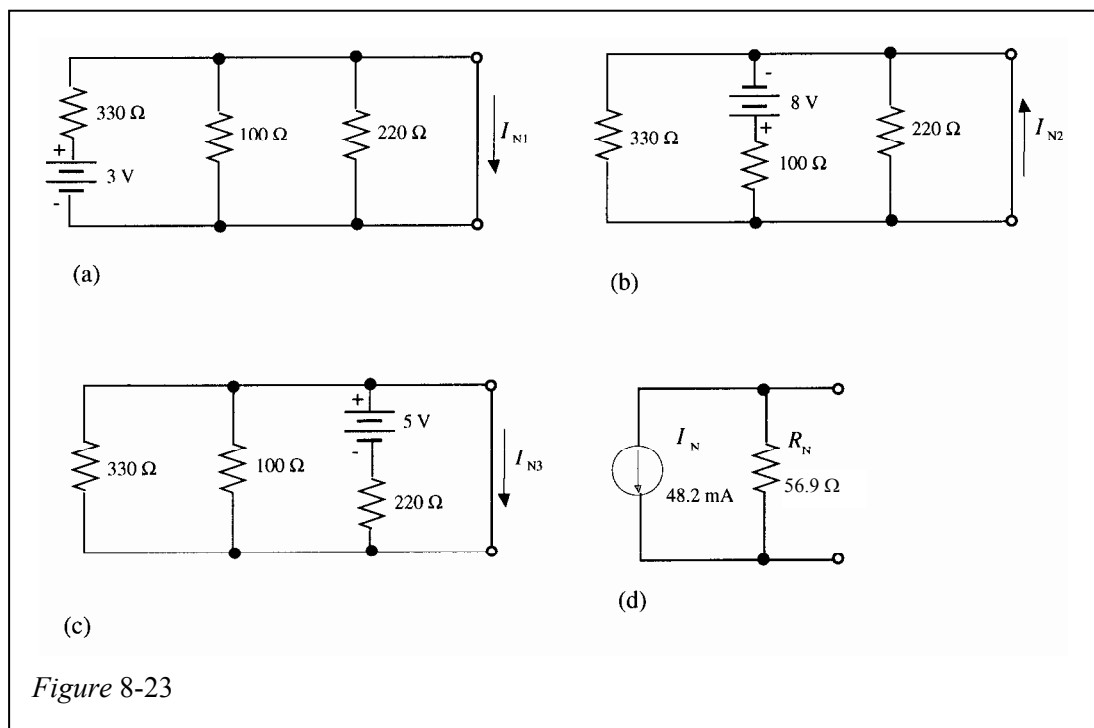
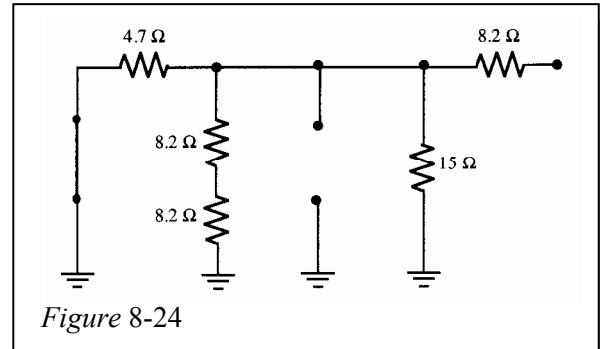

Figure 8-23

Section 8-7 Maximum Power Transfer Theorem

30. (a) $R_L = R_S = 12 \Omega$
 (b) $R_L = R_S = 8.2 \text{ k}\Omega$
 (c) $R_L = R_S = 4.7 \Omega + 1 \Omega \parallel 2 \Omega = 6.37 \Omega$
 (d) $R_L = R_S = 47 \Omega + 680 \Omega = 727 \Omega$

31. See Figure 8-24.
 As seen by R_L :
 $R_S = 8.2 \Omega + 2.94 \Omega = 11.1 \Omega$
 For maximum power transfer:
 $R_L = R_S = 11.1 \Omega$



32. Refer to Problem 31 and Figure 8-24.
 $R_{L+} = R_L + 0.1R_L = 11.1 \Omega + 1.11 \Omega = 12.21 \Omega$
 $R_{TH} = R_S = 11.1 \Omega$
 I_L due to the 1.5 V source:

$$V_{TH} = \left(\frac{15 \Omega \parallel 16.4 \Omega}{4.7 \Omega + 15 \Omega \parallel 16.4 \Omega} \right) 1.5 \text{ V} = \left(\frac{7.79 \Omega}{12.49 \Omega} \right) 1.5 \text{ V} = 936 \text{ mV}$$

$$I_L = \frac{V_{TH}}{R_{TH} + R_{L+}} = \frac{936 \text{ mV}}{23.4 \Omega} = 40 \text{ mA}$$

I_L due to the 1 mA source:

$$I_{15\Omega} = \left(\frac{4.7 \Omega \parallel 16.4 \Omega}{15 \Omega + 4.7 \Omega \parallel 16.4 \Omega} \right) 1 \text{ mA} = \left(\frac{3.65 \Omega}{18.65 \Omega} \right) 1 \text{ mA} = 196 \mu\text{A}$$

$$V_{TH} = I_{15\Omega}(15 \Omega) = (196 \mu\text{A})(15 \Omega) = 2.94 \text{ mV}$$

$$I_L = \frac{V_{TH}}{R_{TH} + R_{L+}} = \frac{2.94 \text{ mV}}{23.4 \Omega} = 126 \mu\text{A}$$

$$I_{L(\text{total})} = 40 \text{ mA} + 126 \mu\text{A} = 40.126 \text{ mA}$$

$$P_L = I_L^2 R_{L+} = (40.126 \text{ mA})^2 12.21 \Omega = 19.7 \text{ mW}$$

Chapter 8

33. For maximum power transfer, $R_{TH} = R_{LADDER}$
The voltage across $R_{TH} = 24$ V (one half of V_{TH})

$$R_{TH} = \frac{24 \text{ V}}{0.5 \text{ A}} = 48 \Omega$$

$$R_{LADDER} = 48 \Omega$$

$$R_{LADDER} = ((R_4 \parallel (R_5 + R_6) + R_3) \parallel R_2) + R_1$$

$$\frac{\left(\frac{69R_4}{69 + R_4} + 10 \right) 47}{47 + \frac{69R_4}{69 + R_4} + 10} = 26$$

$$\frac{69R_4}{69 + R_4} + 10 = \frac{26 \left(\frac{69R_4}{69 + R_4} + 57 \right)}{47}$$

$$\frac{69R_4}{69 + R_4} \left(1 - \frac{26}{47} \right) = \left(\frac{26}{47} \right) 57 - 10 = 21.53$$

$$69R_4 = 69(48.17) + 48.17R_4$$

$$R_4(69 - 48.17) = 69(48.17)$$

$$R_4 = \frac{69(48.17)}{69 - 48.17} = 160 \Omega$$

Section 8-8 Delta-Wye (Δ -Y) and Wye-Delta (Y- Δ) Conversions

34. (a) $R_1 = \frac{R_A R_C}{R_A + R_B + R_C} = \frac{(560 \text{ k}\Omega)(1 \text{ M}\Omega)}{3.06 \text{ M}\Omega} = 183 \text{ k}\Omega$
- $$R_2 = \frac{R_B R_C}{R_A + R_B + R_C} = \frac{(1.5 \text{ M}\Omega)(1 \text{ M}\Omega)}{3.06 \text{ M}\Omega} = 490 \text{ k}\Omega$$
- $$R_3 = \frac{R_A R_B}{R_A + R_B + R_C} = \frac{(560 \text{ k}\Omega)(1.5 \text{ M}\Omega)}{3.06 \text{ M}\Omega} = 275 \text{ k}\Omega$$
- (b) $R_1 = \frac{R_A R_C}{R_A + R_B + R_C} = \frac{(1 \Omega)(2.2 \Omega)}{5.9 \Omega} = 373 \text{ m}\Omega$
- $$R_2 = \frac{R_B R_C}{R_A + R_B + R_C} = \frac{(2.2 \Omega)(2.7 \Omega)}{5.9 \Omega} = 1.01 \Omega$$
- $$R_3 = \frac{R_A R_B}{R_A + R_B + R_C} = \frac{(1 \Omega)(2.7 \Omega)}{5.9 \Omega} = 4.58 \text{ m}\Omega$$

35. (a)
$$R_A = \frac{R_1 R_2 + R_1 R_3 + R_2 R_3}{R_2} = \frac{(12 \Omega)(22 \Omega) + (12 \Omega)(18 \Omega) + (22 \Omega)(18 \Omega)}{22 \Omega} = \frac{876}{22} = 39.8 \Omega$$

$$R_B = \frac{R_1 R_2 + R_1 R_3 + R_2 R_3}{R_1} = \frac{(12 \Omega)(22 \Omega) + (12 \Omega)(18 \Omega) + (22 \Omega)(18 \Omega)}{12 \Omega} = \frac{876}{12} = 73 \Omega$$

$$R_C = \frac{R_1 R_2 + R_1 R_3 + R_2 R_3}{R_3} = \frac{(12 \Omega)(22 \Omega) + (12 \Omega)(18 \Omega) + (22 \Omega)(18 \Omega)}{18 \Omega} = \frac{876}{18} = 48.7 \Omega$$

(b)
$$R_A = \frac{R_1 R_2 + R_1 R_3 + R_2 R_3}{R_2} = \frac{(6.8 \text{ k}\Omega)(3.3 \text{ k}\Omega) + (6.8 \text{ k}\Omega)(4.7 \text{ k}\Omega) + (3.3 \text{ k}\Omega)(4.7 \text{ k}\Omega)}{3.3 \text{ k}\Omega} = 21.2 \text{ k}\Omega$$

$$R_B = \frac{R_1 R_2 + R_1 R_3 + R_2 R_3}{R_1} = \frac{(6.8 \text{ k}\Omega)(3.3 \text{ k}\Omega) + (6.8 \text{ k}\Omega)(4.7 \text{ k}\Omega) + (3.3 \text{ k}\Omega)(4.7 \text{ k}\Omega)}{6.8 \text{ k}\Omega} = 10.3 \text{ k}\Omega$$

$$R_C = \frac{R_1 R_2 + R_1 R_3 + R_2 R_3}{R_3} = \frac{(6.8 \text{ k}\Omega)(3.3 \text{ k}\Omega) + (6.8 \text{ k}\Omega)(4.7 \text{ k}\Omega) + (3.3 \text{ k}\Omega)(4.7 \text{ k}\Omega)}{4.7 \text{ k}\Omega} = 14.9 \text{ k}\Omega$$

36. Convert the delta formed by R_3 , R_4 , and R_5 to a Wye configuration. See Figure 8-25:

$$R_{Y1} = \frac{R_3 R_4}{R_3 + R_4 + R_5} = \frac{(22 \text{ k}\Omega)(12 \text{ k}\Omega)}{43.1 \text{ k}\Omega} = 6.13 \text{ k}\Omega$$

$$R_{Y2} = \frac{R_3 R_5}{R_3 + R_4 + R_5} = \frac{(22 \text{ k}\Omega)(9.1 \text{ k}\Omega)}{43.1 \text{ k}\Omega} = 4.65 \text{ k}\Omega$$

$$R_{Y3} = \frac{R_4 R_5}{R_3 + R_4 + R_5} = \frac{(12 \text{ k}\Omega)(9.1 \text{ k}\Omega)}{43.1 \text{ k}\Omega} = 2.53 \text{ k}\Omega$$

$$R_T = (R_1 + R_{Y1}) \parallel (R_2 + R_{Y2}) + R_{Y3}$$

$$= (10 \text{ k}\Omega + 6.13 \text{ k}\Omega) \parallel (39 \text{ k}\Omega + 4.65 \text{ k}\Omega) + 2.53 \text{ k}\Omega = 11.78 \text{ k}\Omega + 2.53 \text{ k}\Omega = 14.3 \text{ k}\Omega$$

$$I_T = \frac{136 \text{ V}}{R_T} = \frac{136 \text{ V}}{14.3 \text{ k}\Omega} = 9.5 \text{ mA}$$

$$I_{R1} = I_{R_{Y1}} = \left(\frac{R_2 + R_{Y2}}{R_1 + R_{Y1} + R_2 + R_{Y2}} \right) I_T = \left(\frac{43.65 \text{ k}\Omega}{59.78 \text{ k}\Omega} \right) 9.5 \text{ mA} = 6.94 \text{ mA}$$

$$I_{R2} = I_{R_{Y2}} = I_T - I_{R1} = 9.5 \text{ mA} - 6.94 \text{ mA} = 2.56 \text{ mA}$$

$$V_B = V_A - I_{R1} R_1 = 136 \text{ V} - (6.94 \text{ mA})(10 \text{ k}\Omega) = 66.6 \text{ V}$$

$$V_C = V_A - I_{R2} R_2 = 136 \text{ V} - (2.56 \text{ mA})(39 \text{ k}\Omega) = 36.16 \text{ V}$$

In the original circuit:

$$I_{R4} = \frac{V_B}{R_4} = \frac{66.6 \text{ V}}{12 \text{ k}\Omega} = 5.55 \text{ mA}$$

$$I_{R5} = \frac{V_C}{R_5} = \frac{36.16 \text{ V}}{9.1 \text{ k}\Omega} = 3.97 \text{ mA}$$

$$I_{R3} = \frac{V_B - V_C}{R_3} = \frac{66.6 \text{ V} - 36.16 \text{ V}}{22 \text{ k}\Omega} = 1.38 \text{ mA}$$

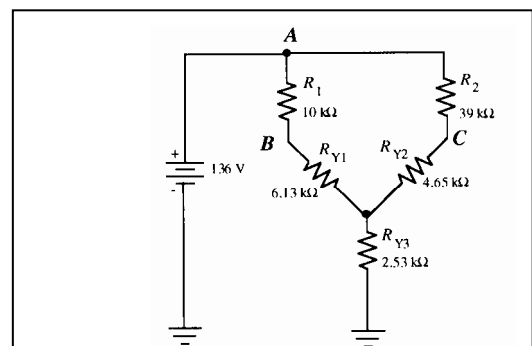

Figure 8-25

Chapter 9

Branch, Loop, and Node Analysis

Note: Solutions show conventional current direction.

Section 9-1 Simultaneous Equations in Circuit Analysis

$$\begin{aligned}
 1. \quad & 100I_1 + 50I_2 = 30 \\
 & 75I_1 + 90I_2 = 15 \\
 & I_1 = \frac{30 - 50I_2}{100} \\
 & 75\left(\frac{30 - 50I_2}{100}\right) + 90I_2 = 15 \\
 & 22.5 - 37.5I_2 + 90I_2 = 15 \\
 & 52.5I_2 = -7.5 \\
 & I_2 = \mathbf{-143 \text{ mA}} \\
 & 100I_1 + 50(-0.143) = 30 \\
 & I_1 = \mathbf{372 \text{ mA}}
 \end{aligned}$$

$$2. \quad (a) \quad \begin{vmatrix} 4 & 6 \\ 2 & 3 \end{vmatrix} = 12 - 12 = \mathbf{0}$$

$$(b) \quad \begin{vmatrix} 9 & -1 \\ 0 & 5 \end{vmatrix} = 45 - 0 = \mathbf{45}$$

$$(c) \quad \begin{vmatrix} 12 & 15 \\ -2 & -1 \end{vmatrix} = -12 - (-30) = \mathbf{18}$$

$$(d) \quad \begin{vmatrix} 100 & 50 \\ 30 & -20 \end{vmatrix} = -2000 - 1500 = \mathbf{-3500}$$

$$3. \quad (a) \quad I_1 = \frac{\begin{vmatrix} 4 & 2 \\ 6 & 3 \\ -1 & 2 \\ 7 & 3 \end{vmatrix}}{\begin{vmatrix} -3 & -14 \end{vmatrix}} = \frac{12 - 12}{-3 - 14} = \mathbf{0 \text{ A}}$$

$$(b) \quad I_2 = \frac{\begin{vmatrix} -1 & 4 \\ 7 & 6 \\ -1 & 2 \\ 7 & 3 \end{vmatrix}}{\begin{vmatrix} -3 & -14 \end{vmatrix}} = \frac{-6 - 28}{-3 - 14} = \mathbf{2 \text{ A}}$$

$$4. \quad (a) \quad \begin{vmatrix} 1 & 0 & -2 & 1 & 0 \\ 5 & 4 & 1 & 5 & 4 \\ 2 & 10 & 0 & 2 & 10 \end{vmatrix}$$

$$\begin{aligned}
 &= (1)(4)(0) + (0)(1)(2) + (-2)(5)(10) - [(2)(4)(-2) + (10)(1)(1) + (0)(5)(0)] \\
 &= (0 + 0 - 100) - (-16 + 10 + 0) = -100 + 6 = \mathbf{-94}
 \end{aligned}$$

$$\begin{aligned}
 (b) \quad & \begin{vmatrix} 0.5 & 1 & -0.8 & 0.5 & 1 \\ 0.1 & 1.2 & 1.5 & 0.1 & 1.2 \\ -0.1 & -0.3 & 5 & -0.1 & -0.3 \end{vmatrix} \\
 &= (0.5)(1.2)(5) + (1)(1.5)(-0.1) + (-0.8)(0.1)(-0.3) \\
 &\quad - [(-0.8)(1.2)(-0.1) + (-0.3)(1.5)(0.5) + (5)(0.1)(1)] \\
 &= (3 - 0.15 + 0.024) - (0.096 - 0.255 + 0.5) = 2.874 - 0.371 = \mathbf{2.50}
 \end{aligned}$$

Chapter 9

$$\begin{aligned}
 5. \quad (a) \quad & \begin{vmatrix} 25 & 0 & -20 & | & 25 & 0 \\ 10 & 12 & 5 & | & 10 & 12 \\ -8 & 30 & -16 & | & -8 & 30 \end{vmatrix} \\
 & = 25(12)(-16) + (0)(5)(-8) + (-20)(10)(30) \\
 & \quad - [(-8)(12)(-20) + (30)(5)(25) + (-16)(10)(0)] \\
 & = -10800 - 5670 = \mathbf{-16,470}
 \end{aligned}$$

$$\begin{aligned}
 (b) \quad & \begin{vmatrix} 1.08 & 1.75 & 0.55 & | & 1.08 & 1.75 \\ 0 & 2.12 & -0.98 & | & 0 & 2.12 \\ 1 & 3.49 & -1.05 & | & 1 & 3.49 \end{vmatrix} \\
 & = (1.08)(2.12)(-1.05) + (1.75)(-0.98)(1) + (0.55)(0)(3.49) \\
 & \quad - [(1)(2.12)(0.55) + (3.49)(-0.98)(1.08) + (1.05)(0)(1.75)] \\
 & = -4.119 + 2.528 = \mathbf{-1.591}
 \end{aligned}$$

6. The characteristic determinant was evaluated as 2.35 in Example 9-4. The determinant for I_3 is as follows:

$$\begin{aligned}
 & \begin{vmatrix} 2 & 0.5 & 0 & | & 2 & 0.5 \\ 0.75 & 0 & 1.5 & | & 0.75 & 0 \\ 3 & 0.2 & -1 & | & 3 & 0.2 \end{vmatrix} = (0 + 2.25 + 0) - (0 + 0.6 - 0.375) = 2.25 - 0.225 = 2.025 \\
 I_3 & = \frac{2.025}{2.35} = \mathbf{862 \text{ mA}}
 \end{aligned}$$

7. The characteristic determinant is:

$$\begin{aligned}
 & \begin{vmatrix} 2 & -6 & 10 & | & 2 & -6 \\ 3 & 7 & -8 & | & 3 & 7 \\ 10 & 5 & -12 & | & 10 & 5 \end{vmatrix} \\
 & = (2)(7)(-12) + (-6)(-8)(10) + (10)(3)(5) \\
 & \quad - [(10)(7)(10) + (5)(-8)(2) + (-12)(3)(-6)] \\
 & = 462 - 836 = \mathbf{-374}
 \end{aligned}$$

$$\begin{aligned}
 I_1 & = \frac{\begin{vmatrix} 9 & -6 & 10 & | & 9 & -6 \\ 3 & 7 & -8 & | & 3 & 7 \\ 0 & 5 & -12 & | & 0 & 5 \end{vmatrix}}{-374} \\
 & = \frac{(9)(7)(-12) + (-6)(-8)(0) + (10)(3)(5) - [(0)(7)(10) + (5)(-8)(9) + (-12)(3)(-6)]}{-374} \\
 & = \frac{-606 + 144}{-374} = \frac{-462}{-374} = \mathbf{1.24 \text{ A}}
 \end{aligned}$$

$$\begin{aligned}
 I_2 &= \frac{\begin{vmatrix} 2 & 9 & 10 & 2 & 9 \\ 3 & 3 & -8 & 3 & 3 \\ 10 & 0 & -12 & 10 & 0 \end{vmatrix}}{-374} \\
 &= \frac{(2)(3)(-12) + (9)(-8)(10) + (10)(3)(0) - [(10)(3)(10) + (0)(-8)(2) + (-12)(3)(9)]}{-374} \\
 &= \frac{-792 + 24}{-374} = \frac{-768}{-374} = \mathbf{2.05 \text{ A}}
 \end{aligned}$$

$$\begin{aligned}
 I_3 &= \frac{\begin{vmatrix} 2 & -6 & 9 & 2 & -6 \\ 3 & 7 & 3 & 3 & 7 \\ 10 & 5 & 0 & 10 & 5 \end{vmatrix}}{-374} \\
 &= \frac{(2)(7)(0) + (-6)(3)(10) + (9)(3)(5) - [(10)(7)(9) + (5)(3)(2) + (0)(3)(-6)]}{-374} \\
 &= \frac{-45 - 660}{-374} = \frac{-705}{-374} = \mathbf{1.89 \text{ A}}
 \end{aligned}$$

8. The calculator results are:

$$\begin{aligned}
 V_1 &= 1.61301369863 \\
 V_2 &= -1.69092465753 \\
 V_3 &= -2.52397260274 \\
 V_4 &= 4.69691780822
 \end{aligned}$$

9. $X1 = .371428571429$ ($I_1 = 371 \text{ mA}$)
 $X2 = -.142857142857$ ($I_2 = -143 \text{ mA}$)
10. $X1 = 1.23529411765$ ($I_1 = 1.24 \text{ A}$)
 $X2 = 2.05347593583$ ($I_2 = 2.05 \text{ A}$)
 $X3 = 1.88502673797$ ($I_3 = 1.89 \text{ A}$)

Section 9-2 Branch Current Method

11. The sum of the currents at the node is zero. Currents into the node are assumed positive and currents out of the node are assumed negative.

$$I_1 - I_2 - I_3 = 0$$

12. $I_1 - I_2 - I_3 = 0$
 $8.2I_1 + 10I_2 = 12$
 $-10I_2 + 5.6I_3 = -6$
 Solving by substitution:
 $I_1 = I_2 + I_3$
 $8.2(I_2 + I_3) + 10I_2 = 12$
 $8.2I_2 + 8.2I_3 = 10I_2 = 12$

Chapter 9

$$18.2I_2 + 8.2I_3 = 12$$

$$I_2 = \frac{12 - 8.2I_3}{18.2}$$

$$-10\left(\frac{12 - 8.2I_3}{18.2}\right) + 5.6I_3 = -6$$

$$\frac{120 - 82I_3}{18.2} + 5.6I_3 = -6$$

$$10.11I_3 = 0.59$$

$$I_3 = \mathbf{58.4 \text{ mA}}$$

$$-10I_2 + 5.6(0.058) = -6$$

$$-10I_2 + 0.325 = -6$$

$$I_2 = 633 \text{ mA}$$

$$I_1 = I_2 + I_3 = 633 \text{ mA} + 58.4 \text{ mA} = \mathbf{691 \text{ mA}}$$

13. The branch currents were found in Problem 12.

$$I_1 = 691 \text{ mA}$$

$$I_2 = 633 \text{ mA}$$

$$I_3 = 58.4 \text{ mA}$$

$$V_1 = I_1R_1 = (691 \text{ mA})(8.2 \Omega) = \mathbf{5.66 \text{ V}}$$
 (+ on left)

$$V_2 = I_2R_2 = (633 \text{ mA})(10 \Omega) = \mathbf{6.33 \text{ V}}$$
 (+ at top)

$$V_3 = I_3R_3 = (58.4 \text{ mA})(5.6 \Omega) = \mathbf{325 \text{ mV}}$$
 (+ on left)

14. $I_1 - I_2 = 100 \text{ mA}$

$$\frac{12 - V_A}{47} - \frac{V_A}{100} = 0.1$$

$$100(12 - V_A) - 47V_A = 470$$

$$1200 - 100V_A - 47V_A = 470$$

$$-147V_A = -730$$

$$V_A = 4.97$$

$$I_1 = \frac{12 \text{ V} - 4.97 \text{ V}}{47 \Omega} = \frac{7.03 \text{ V}}{47 \Omega} = \mathbf{150 \text{ mA}}$$

$$I_2 = \frac{4.97 \text{ V}}{100 \Omega} = \mathbf{49.7 \text{ mA}}$$

$$I_3 = \mathbf{100 \text{ mA}}$$
 (current source)

15. Current source zeroed (open). See Figure 9-1(a).

$$V_{AB} = V_2 = \left(\frac{R_2}{R_1 + R_2}\right)V_S = \left(\frac{100 \Omega}{147 \Omega}\right)12 \text{ V} = 8.16 \text{ V}$$

Voltage source zeroed (shorted). See Figure 9-1(b).

$$V_{AB} = V_3 = I_3R_3 = (100 \text{ mA})(68 \Omega) = 6.8 \text{ V}$$

$$I_2 = \left(\frac{R_1}{R_1 + R_2}\right)I_S = \left(\frac{47 \Omega}{147 \Omega}\right)100 \text{ mA} = 31.97 \text{ mA}$$

$$V_{AG} = V_2 = -(31.97 \text{ mA})(100 \Omega) = -3.197 \text{ V}$$

$$V_{AB} = V_{AG} - V_{BG} = -3.197 - 6.8 \text{ V} = -9.997 \text{ V}$$

Superimposing:

$$V_{AB} = 8.16 \text{ V} + (-9.997 \text{ V}) = \mathbf{-1.84 \text{ V}}$$

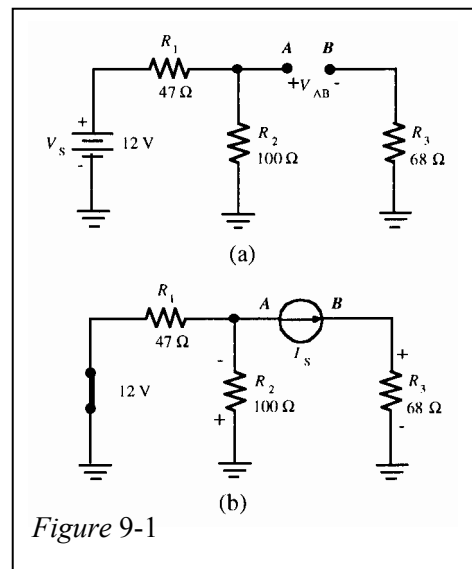

Figure 9-1

Section 9-3 Loop Current Method

16. The characteristic determinant is:

$$\begin{vmatrix} 0.045 & 0.130 & 0.066 \\ 0.177 & 0.042 & 0.109 \\ 0.078 & 0.196 & 0.290 \end{vmatrix} \begin{vmatrix} 0.045 & 0.130 \\ 0.177 & 0.042 \\ 0.078 & 0.196 \end{vmatrix}$$

$$\begin{aligned} &= (0.045)(0.042)(0.290) + (0.130)(0.109)(0.078) + (0.066)(0.177)(0.196) \\ &\quad - [(0.078)(0.042)(0.066) + (0.196)(0.109)(0.045) + (0.290)(0.177)(0.130)] \\ &= 0.00394 - 0.00785 = \mathbf{-0.00391} \end{aligned}$$

17. $1560I_1 - 560I_2 = -6$
 $-560I_1 + 1380I_2 = -2$

$$I_1 = \frac{\begin{vmatrix} -6 & -560 \\ -2 & 1380 \end{vmatrix}}{\begin{vmatrix} 1560 & -560 \\ -560 & 1380 \end{vmatrix}} = \frac{-8280 - 1120}{2,152,800 - 313,600} = \frac{-9400}{1,839,200} = \mathbf{-5.11 \text{ mA}}$$

$$I_2 = \frac{\begin{vmatrix} 1560 & -6 \\ -560 & -2 \end{vmatrix}}{1,839,200} = \frac{-3180 - 3360}{1,839,200} = \mathbf{-3.52 \text{ mA}}$$

18. Using the loop currents from Problem 17:

$$I_{1 \text{ k}\Omega} = I_1 = \mathbf{-5.11 \text{ mA}}$$

$$I_{820 \Omega} = I_2 = \mathbf{-352 \text{ mA}}$$

$$I_{560 \Omega} = I_1 - I_2 = -5.11 \text{ mA} + 3.52 \text{ mA} = \mathbf{1.59 \text{ mA}}$$

19. Using the branch currents from Problem 18:

$$V_{1 \text{ k}\Omega} = I_{1 \text{ k}\Omega}(1 \text{ k}\Omega) = (5.11 \text{ mA})(1 \text{ k}\Omega) = \mathbf{5.11 \text{ V}} \text{ (+ on right)}$$

$$V_{560 \Omega} = I_{560 \Omega}(560 \Omega) = (1.59 \text{ mA})(560 \Omega) = \mathbf{890 \text{ mV}} \text{ (+ on bottom)}$$

$$V_{820 \Omega} = I_{820 \Omega}(820 \Omega) = (3.52 \text{ mA})(820 \Omega) = \mathbf{2.89 \text{ V}} \text{ (+ on right)}$$

20. $57I_1 - 10I_2 = 1.5$
 $-10I_1 + 41.7I_2 - 4.7I_3 = -3$
 $-4.7I_2 + 19.7I_3 = 1.5$

Chapter 9

21. The equations were developed in Problem 20. The characteristic determinant is as follows with the $k\Omega$ units omitted for simplicity:

$$\begin{vmatrix} 57 & -10 & 0 \\ -10 & 41.7 & -4.7 \\ 0 & -4.7 & 19.7 \end{vmatrix} \begin{vmatrix} 57 & -10 \\ -10 & 41.7 \\ 0 & -4.7 \end{vmatrix}$$
$$= (57)(41.7)(19.7) + (-10)(-4.7)(0) + (0)(-10)(-4.7) \\ - [(0)(41.7)(0) + (-4.7)(-4.7)(57) + (19.7)(-10)(-10)] \\ = 46,824.93 - 3,229.13 = 43,595.8$$

$$43,595.8I_1 = \begin{vmatrix} 1.5 & -10 & 0 \\ -3 & 41.7 & -4.7 \\ 1.5 & -4.7 & 19.7 \end{vmatrix} \begin{vmatrix} 1.5 & -10 \\ -3 & 41.7 \\ 1.5 & -4.7 \end{vmatrix}$$
$$= (1.5)(41.7)(19.7) + (-10)(-4.7)(1.5) + (0)(-3)(-4.7) \\ - [(1.5)(41.7)(0) + (-4.7)(-4.7)(1.5) + (19.7)(-3)(-10)] \\ I_1 = \frac{1302.735 - 624.135}{43,595.8} = \frac{678.6}{43,595.8} = \mathbf{15.6 \text{ mA}}$$

$$43,595.8I_2 = \begin{vmatrix} 57 & 1.5 & 0 \\ -10 & -3 & -4.7 \\ 0 & 1.5 & 19.7 \end{vmatrix} \begin{vmatrix} 57 & 1.5 \\ -10 & -3 \\ 0 & 1.5 \end{vmatrix}$$
$$= (57)(-3)(19.7) + (1.5)(-4.7)(0) + (0)(-10)(1.5) \\ - [(0)(-3)(0) + (1.5)(-4.7)(57) + (19.7)(-10)(1.5)] \\ I_2 = \frac{-3368.7 + 697.35}{43,595.8} = \frac{-2671.35}{43,595.8} = \mathbf{-61.3 \text{ mA}}$$

Substituting into the third equation to get I_3 :

$$19.7I_3 = 1.5 + 4.7I_2$$

$$I_3 = \frac{1.5 + 4.7(-0.0613 \text{ A})}{19.7} = \mathbf{61.5 \text{ mA}}$$

22. Use the loop currents from Problem 21:

$$I_{47\Omega} = I_1 = \mathbf{15.6 \text{ mA}}$$

$$I_{27\Omega} = I_2 = \mathbf{-61.3 \text{ mA}}$$

$$I_{15\Omega} = I_3 = \mathbf{61.5 \text{ mA}}$$

$$I_{10\Omega} = I_1 - I_2 = 15.6 \text{ mA} - (-61.3 \text{ mA}) = \mathbf{76.9 \text{ mA}}$$

$$I_{4.7\Omega} = I_2 - I_3 = -61.3 \text{ mA} - 61.5 \text{ mA} = \mathbf{123 \text{ mA}}$$

23. See Figure 9-2.

The loop equations are:

$$(10 + 4.7 + 2.2)I_1 - (4.7 + 2.2)I_2 = 8 \text{ V}$$

$$(2.2 + 4.7 + 8.2 + 3.9)I_2 - (2.2 + 4.7)I_1 = 0 \text{ V}$$

$$16.9I_1 - 6.9I_2 = 8$$

$$-6.9I_1 + 19I_2 = 0$$

$$I_1 = \frac{\begin{vmatrix} 8 & -6.9 \\ 0 & 19 \end{vmatrix}}{\begin{vmatrix} 16.9 & -6.9 \\ -6.9 & 19 \end{vmatrix}} = \frac{(8)(19)}{(16.9)(19) - (6.9)(6.9)} = \frac{152}{321.1 - 47.61} = \frac{152}{273.49} = 555 \text{ mA}$$

$$I_2 = \frac{\begin{vmatrix} 16.9 & 8 \\ -6.9 & 0 \end{vmatrix}}{\begin{vmatrix} 16.9 & -6.9 \\ -6.9 & 19 \end{vmatrix}} = \frac{-(8)(-6.9)}{(16.9)(19) - (6.9)(6.9)} = \frac{55.2}{321.1 - 47.61} = \frac{55.2}{273.49} = 202 \text{ mA}$$

$$V_A = (I_1 - I_2)2.2 \Omega = (555 \text{ mA} - 202 \text{ mA})2.2 \Omega = (353 \text{ mA})2.2 \Omega = 776.6 \text{ mV}$$

$$V_B = I_2(3.9 \Omega) = (202 \text{ mA})(3.9 \Omega) = 787.8 \text{ mV}$$

$$V_{AB} = V_A - V_B = 776.6 \text{ mV} - 787.8 \text{ mV} = \mathbf{-11.2 \text{ mV}}$$

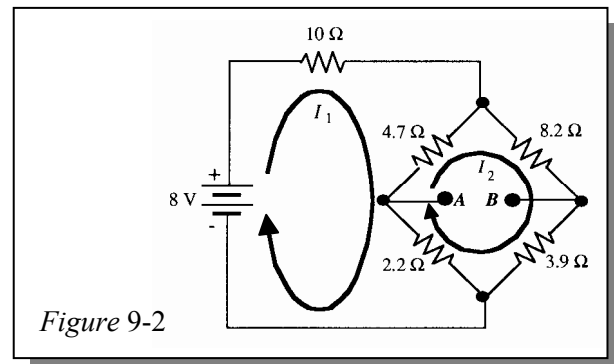

Chapter 9

24. See Figure 9-3.

The loop equations are:

$$(10 + 4.7 + 2.2)I_1 - 4.7I_2 - 2.2I_3 = 8 \text{ V}$$

$$(4.7 + 8.2 + 10)I_2 - 4.7I_1 - 10I_3 = 0$$

$$(2.2 + 10 + 3.9)I_3 - 2.2I_1 - 10I_2 = 0$$

$$16.9I_1 - 4.7I_2 - 2.2I_3 = 8 \text{ V}$$

$$-4.7I_1 + 22.9I_2 - 10I_3 = 0$$

$$-2.2I_1 - 10I_2 + 16.1I_3 = 0$$

The characteristic determinant is:

$$\begin{vmatrix} 16.9 & -4.7 & -2.2 \\ -4.7 & 22.9 & -10 \\ -2.2 & -10 & 16.1 \end{vmatrix} \begin{vmatrix} 16.9 & -4.7 \\ -4.7 & 22.9 \\ -2.2 & -10 \end{vmatrix}$$

$$\begin{aligned} &= (16.9)(22.9)(16.1) + (-4.7)(-10)(-2.2) + (-2.2)(-4.7)(-10) \\ &\quad - [(-2.2)(22.9)(-2.2) + (-10)(-10)(16.9) + (16.1)(-4.7)(-4.7)] \\ &= 6024.061 - 2156.485 = 3867.576 \end{aligned}$$

$$\begin{aligned} 3867.576I_2 &= \begin{vmatrix} 16.9 & 8 & -2.2 \\ -4.7 & 0 & -10 \\ -2.2 & 0 & 16.1 \end{vmatrix} \begin{vmatrix} 16.9 & 8 \\ -4.7 & 0 \\ -2.2 & 0 \end{vmatrix} \\ &= (16.9)(0)(16.1) + (8)(-10)(-2.2) + (-2.2)(-4.7)(0) \\ &\quad - [(-2.2)(0)(-2.2) + (0)(-10)(16.9) + (16.1)(-4.7)(8)] \end{aligned}$$

$$I_2 = \frac{176 + 605.36}{3867.576} = \frac{781.36}{3867.576} = \mathbf{202 \text{ mA}}$$

$$\begin{aligned} 3867.576I_3 &= \begin{vmatrix} 16.9 & -4.7 & 8 \\ -4.7 & 22.9 & 0 \\ -2.2 & -10 & 0 \end{vmatrix} \begin{vmatrix} 16.9 & -4.7 \\ -4.7 & 22.9 \\ -2.2 & -10 \end{vmatrix} \\ &= (16.9)(22.9)(0) + (-4.7)(0)(-2.2) + (8)(-4.7)(-10) \\ &\quad - [(-2.2)(22.9)(8) + (-10)(0)(16.9) + (0)(-4.7)(-4.7)] \end{aligned}$$

$$I_3 = \frac{376 + 403.04}{3867.576} = \frac{779.04}{3867.576} = \mathbf{201 \text{ mA}}$$

$$I_{BA} = I_2 - I_3 = 202 \text{ mA} - 201 \text{ mA} = \mathbf{1 \text{ mA}}$$

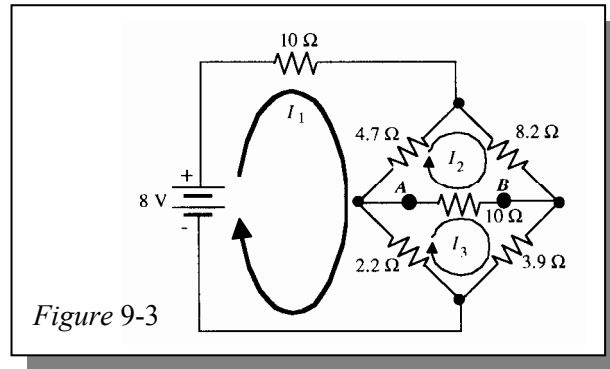

Figure 9-3

25. See Figure 9-4.

$$\begin{aligned}(R_1 + R_2 + R_3)I_A - R_2I_B - R_3I_C &= 0 \\ -R_2I_A + (R_2 + R_4)I_B - R_4I_C &= V_S \\ -R_3I_A - R_4I_B + (R_3 + R_4 + R_L)I_C &= 0\end{aligned}$$

$$\begin{aligned}5.48I_A - 3.3I_B - 1.5I_C &= 0 \\ -3.3I_A + 4.12I_B - 0.82I_C &= 15 \\ -1.5I_A - 0.82I_B + 4.52I_C &= 0\end{aligned}$$

Coefficients are in kΩ.

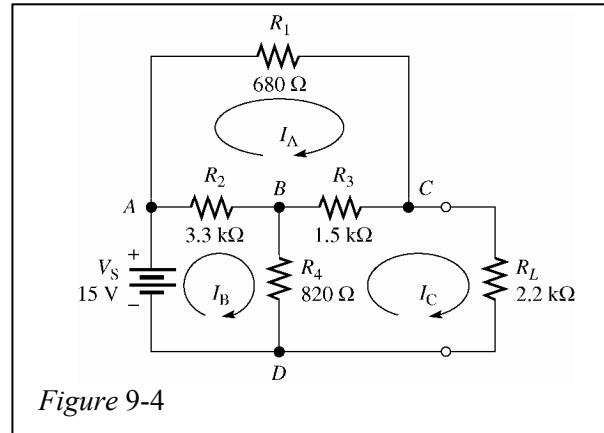

Figure 9-4

Section 9-4 Node Voltage Method

26. See Figure 9-5.

The current equation at node A is:

$$I_1 - I_2 - I_3 = 0$$

Using Ohm's law substitutions for the currents:

$$\begin{aligned}\frac{30 - V_A}{82} - \frac{V_A - 40}{68} - \frac{V_A}{147} &= 0 \\ \frac{30}{82} - \frac{V_A}{82} - \frac{V_A}{68} + \frac{40}{60} - \frac{V_A}{147} &= 0\end{aligned}$$

Multiply each term in the last equation by $(82)(68)(147) = 819,672$ to eliminate the denominators.

$$\begin{aligned}9996(30) - 9996V_A - 12,054V_A + 12,054 - 5576V_A &= 0 \\ 782,040 - 27,626V_A &= 0\end{aligned}$$

$$V_{AB} = V_A = \frac{782,040}{27,626} = \mathbf{28.3 \text{ V}}$$

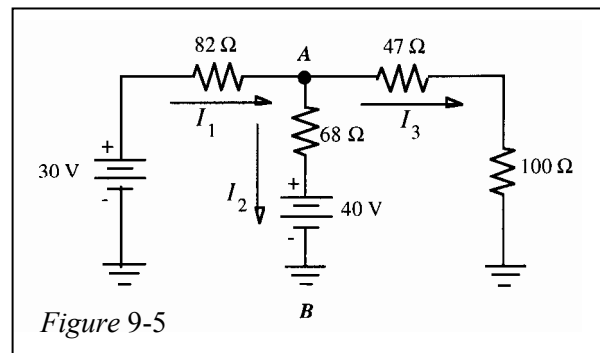

Figure 9-5

27. Use $V_{AB} = 28.3 \text{ V}$ from Problem 26.

$$I_1 = \frac{30 \text{ V} - V_{AB}}{82 \Omega} = \frac{30 \text{ V} - 28.3 \text{ V}}{82 \Omega} = \mathbf{20.6 \text{ mA}}$$

$$I_2 = \frac{V_{AB} - 40 \text{ V}}{68 \Omega} = \frac{28.3 \text{ V} - 40 \text{ V}}{68 \Omega} = \mathbf{-172 \text{ mA}}$$

$$I_3 = \frac{V_{AB}}{147 \Omega} = \frac{28.3 \text{ V}}{147 \Omega} = \mathbf{193 \text{ mA}}$$

Chapter 9

28. See Figure 9-6.

$$I_1 - I_2 - I_3 = 0$$

$$I_3 + I_4 - I_5 = 0$$

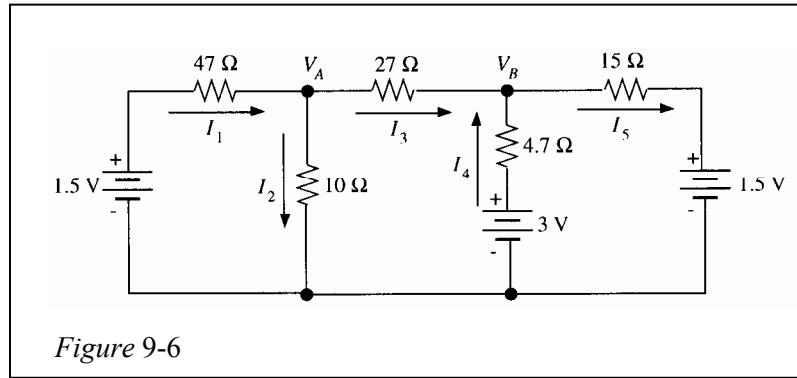

Figure 9-6

Substituting into the first equation and simplifying:

$$\frac{1.5 - V_A}{47} - \frac{V_A}{10} - \frac{V_A - V_B}{27} = 0$$

$$\frac{1.5}{47} - \frac{V_A}{47} - \frac{V_A}{10} - \frac{V_A}{27} + \frac{V_B}{27} = 0$$

$$\frac{-27V_A - 126.9V_A - 47V_A}{126.9} + \frac{V_B}{27} = \frac{-1.5}{47}$$

$$\frac{200.9V_A}{126.9} - \frac{V_B}{27} = \frac{1.5}{47}$$

$$1.58V_A - 0.037V_B = 0.0319$$

Substituting into the second equation and simplifying:

$$\frac{V_A - V_B}{27} + \frac{3 - V_B}{4.7} - \frac{V_B - 1.5}{15} = 0$$

$$\frac{V_A}{27} - \frac{V_B}{27} + \frac{3}{4.7} - \frac{V_B}{4.7} - \frac{V_B}{15} + \frac{1.5}{5} = 0$$

$$0.037V_A - 0.037V_B - 0.213V_B - 0.067V_B + 0.738$$

$$0.037V_A - 0.317V_B = -0.738$$

29. See Figure 9-7.

Node A: $I_1 - I_2 - I_3 = 0$

Node B: $I_3 - I_4 - I_5 = 0$

$$I_1 = \frac{9\text{ V} - V_A}{R_1}$$

$$I_2 = \frac{V_A}{R_2}$$

$$I_3 = \frac{V_A - V_B}{R_3}$$

$$I_4 = \frac{V_B + 4.5\text{ V}}{R_4}$$

$$I_5 = \frac{V_B + 1.5\text{ V}}{R_5}$$

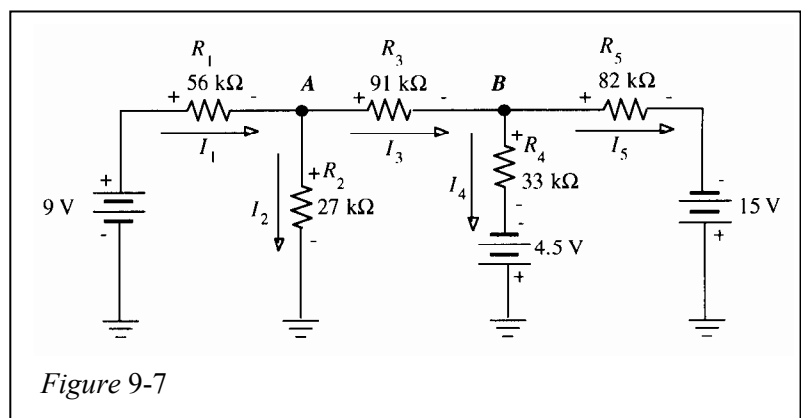

Figure 9-7

$$\begin{aligned}
 \text{Node A: } & \frac{9-V_A}{56} - \frac{V_A}{27} - \frac{V_A-V_B}{91} = 0 \\
 & \frac{9}{56} - \frac{V_A}{56} - \frac{V_A}{27} - \frac{V_A}{91} + \frac{V_B}{91} = 0 \\
 & \frac{-2457V_A - 5096V_A - 1512V_A}{137,592} + \frac{V_B}{91} + \frac{9}{56} = 0 \\
 & -\left(\frac{9065}{137,592}\right)V_A + \left(\frac{1}{91}\right)V_B + \frac{9}{56} = 0 \\
 & -0.0659V_A + 0.0109V_B = -0.1607
 \end{aligned}$$

$$\begin{aligned}
 \text{Node B: } & \frac{V_A-V_B}{91} - \frac{V_B+4.5}{33} - \frac{V_B+15}{82} = 0 \\
 & \frac{V_A}{91} - \frac{V_B}{91} - \frac{V_B}{33} - \frac{4.5}{33} - \frac{V_B}{82} - \frac{15}{82} = 0 \\
 & \frac{V_A}{91} + \frac{-2706V_A - 7462V_B - 3003V_A}{246,246} + \frac{-(32)(4.5) - (33)(15)}{2706} = 0 \\
 & \frac{V_A}{91} - \frac{131,171V_B}{246,246} - \frac{864}{2706} = 0 \\
 & 0.0109V_A - 0.0535V_B = 0.3193
 \end{aligned}$$

The characteristic determinant is:

$$\begin{vmatrix} -0.0659 & 0.0109 \\ 0.0109 & -0.0535 \end{vmatrix} = 0.0035 - 0.0001 = 0.0034$$

$$0.0034V_A = \begin{vmatrix} -0.1607 & 0.0109 \\ 0.3193 & -0.0535 \end{vmatrix} = 0.0086 - 0.0035 = 0.0051$$

$$V_A = \frac{0.0051}{0.0034} = \mathbf{1.5 \text{ V}}$$

$$0.0034V_B = \begin{vmatrix} -0.0659 & 0.1607 \\ 0.0109 & -0.3193 \end{vmatrix} = 0.0210 - 0.0018 = -0.0192$$

$$V_B = \frac{-0.0192}{0.0034} = \mathbf{-5.65 \text{ V}}$$

Chapter 9

30. See Figure 9-8.

Node A: $I_1 - I_2 + I_3 + I_4 = 0$

Node B: $I_2 + I_5 - I_6 = 0$

Node C: $-I_3 + I_7 + I_8 = 0$

$$I_1 = \frac{24 \text{ V} - V_A}{1 \text{ k}\Omega} \quad I_5 = \frac{24 \text{ V} - V_B}{1 \text{ k}\Omega}$$

$$I_2 = \frac{V_A - V_B}{1 \text{ k}\Omega} \quad I_6 = \frac{V_B - 18 \text{ V}}{1 \text{ k}\Omega}$$

$$I_3 = \frac{V_C - V_A}{1 \text{ k}\Omega} \quad I_7 = \frac{10 \text{ V} - V_C}{1 \text{ k}\Omega}$$

$$I_4 = \frac{V_A}{1 \text{ k}\Omega} \quad I_8 = \frac{18 \text{ V} - V_C}{1 \text{ k}\Omega}$$

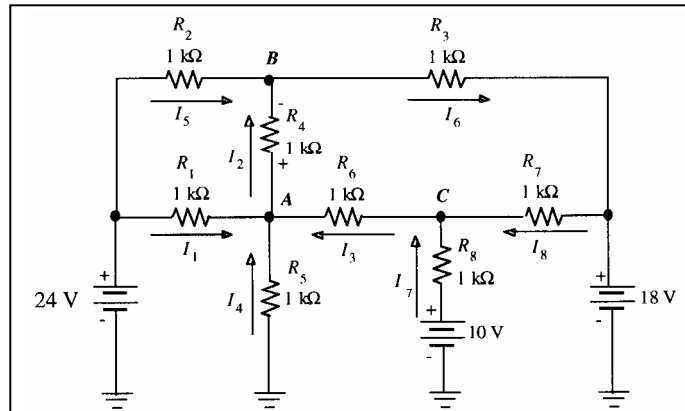

Figure 9-8

The kΩ and V units are omitted for simplicity and the denominators are all 1.

Node A: $(24 - V_A) - (V_A - V_B) + (V_C - V_A) - V_A = 0$
 $-4V_A + V_B + V_C = -24$

Node B: $(V_A - V_B) + (24 - V_B) + (V_B - 18) = 0$
 $V_A - 3V_B = -42$

Node C: $-(V_C - V_A) + (10 - V_C) + (18 - V_C) = 0$
 $V_A - 3V_C = -28$

The characteristic determinant is:

$$\begin{vmatrix} -4 & 1 & 1 \\ 1 & -3 & 0 \\ 1 & 0 & -3 \end{vmatrix} = (-4)(-3)(-3) - (1)(-3)(1) - (1)(1)(-3) = -36 + 3 + 3 = -30$$

$$\begin{aligned} -30V_A &= \begin{vmatrix} -24 & 1 & 1 \\ -42 & -3 & 0 \\ -28 & 0 & -3 \end{vmatrix} = (-24)(-3)(-3) - (-28)(-3)(1) - (1)(-42)(-3) = -2166 - 84 - 126 \\ &= -426 \end{aligned}$$

$$V_A = \frac{-426}{-30} = 14.2 \text{ V}$$

$$\begin{aligned} -30V_B &= \begin{vmatrix} -4 & -24 & 1 \\ 1 & -42 & 0 \\ 1 & -28 & -3 \end{vmatrix} = (-4)(-42)(-3) + (1)(-28)(1) - (1)(-42)(1) - (-42)(1)(-3) \\ &= -504 - 28 + 42 - 72 = -562 \end{aligned}$$

$$V_B = \frac{-562}{-30} = 18.7 \text{ V}$$

$$-30V_C = \begin{vmatrix} -4 & 1 & -24 \\ 1 & -3 & 42 \\ 1 & 0 & -28 \end{vmatrix} = (-4)(-3)(-28) + (1)(-42)(1) - (1)(-3)(-24) - (1)(1)(-28)$$

$$= -336 - 42 - 72 - 28 = -422$$

$$V_C = \frac{-422}{-30} = 14.1 \text{ V}$$

31. See Figure 9-9.

$$I_7 = \frac{4.32 \text{ V}}{2 \text{ k}\Omega} = 2.16 \text{ mA}$$

$$V_C = +4.32 \text{ V} - 20 \text{ V} = -15.7 \text{ V}$$

$$I_6 = \frac{-5.25 \text{ V} - (-15.7 \text{ V})}{20 \text{ k}\Omega} = \frac{10.43 \text{ V}}{20 \text{ k}\Omega} = 522 \text{ }\mu\text{A}$$

$$I_4 = \frac{5.25 \text{ V}}{16 \text{ k}\Omega} = 328 \text{ }\mu\text{A}$$

$$I_1 = I_6 - I_4 = 522 \text{ }\mu\text{A} - 328 \text{ }\mu\text{A} = 193 \text{ }\mu\text{A}$$

$$V_A = -5.25 \text{ V} + (193 \text{ }\mu\text{A})(8 \text{ k}\Omega) = -5.25 \text{ V} + 1.55 \text{ V} = -3.70 \text{ V}$$

$$I_2 = \frac{3.70 \text{ V}}{10 \text{ k}\Omega} = 370 \text{ }\mu\text{A}$$

$$I_5 = I_7 - I_4 - I_2 = 2.16 \text{ mA} - 328 \text{ }\mu\text{A} - 370 \text{ }\mu\text{A} = 1.46 \text{ mA}$$

$$V_B = -(1.46 \text{ mA})(4 \text{ k}\Omega) = -5.85 \text{ V}$$

$$I_3 = \frac{V_A - V_B}{12 \text{ k}\Omega} = \frac{-3.70 \text{ V} - (-5.85 \text{ V})}{12 \text{ k}\Omega} = \frac{2.14 \text{ V}}{12 \text{ k}\Omega} = 179 \text{ }\mu\text{A}$$

$$I_8 = I_3 + I_5 = 179 \text{ }\mu\text{A} + 1.46 \text{ mA} = 1.64 \text{ mA}$$

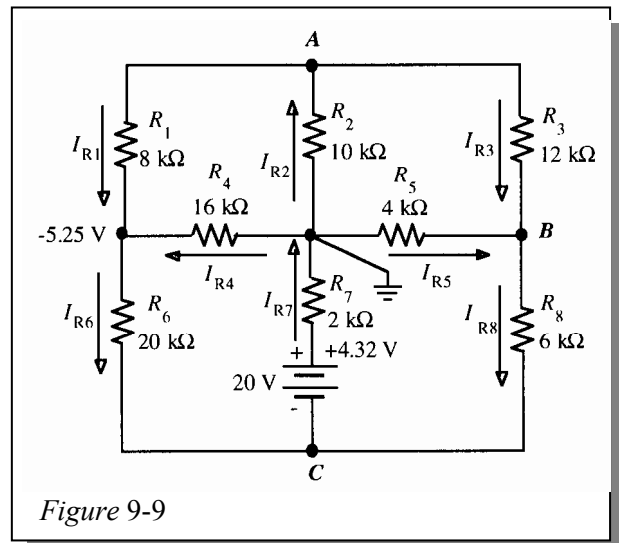

Figure 9-9